

### Stainless Steel Counter

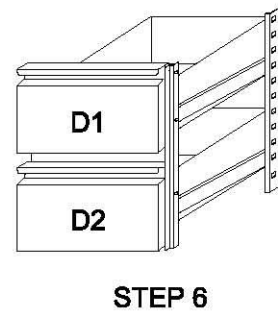

- UK Stainless Steel Counter Refrigerators/  
Freezers (Only for kitchen equipment)  
Instruction manual
- IT Banchi frigoriferi / congelatori a banco in  
acciaio inossidabile (Solo per attrezzatura  
da cucina)  
Manuale di istruzioni
- ES Frigoríficos / Congeladores de mostrador  
de acero inoxidable (Solo para equipos  
de cocina )  
Manual de instrucciones
- FR Comptoirs réfrigérantes / congélateurs  
inox (Seulement pour l'équipement de  
cuisine)  
Mode d'emploi
- NL RVS werkbanken met koeling  
vriezer (Alleen voor keukenapparatuur )  
Handleiding
- DE Edelstahl-kühl-/Tiefkühlische (Nur für  
Küchengeräte )  
Bedienungsanleitung
- PT Frigoríficos/congeladores balcão em  
aço inoxidável (Somente para  
equipamentos de cozinha)  
Manual de instruções
- RUS Холодильные и морозильные столы  
из нержавеющей стали (Только для  
кухонного оборудования)  
Инструкция по эксплуатации

# SET 2 DRAWER ASSEMBLY GUIDE - 2x1/2

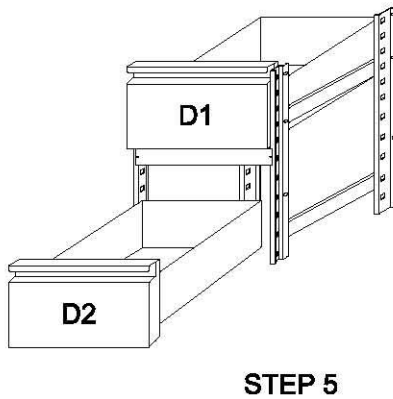
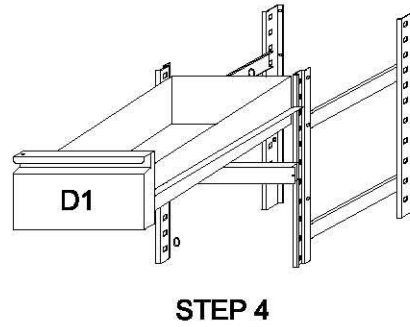
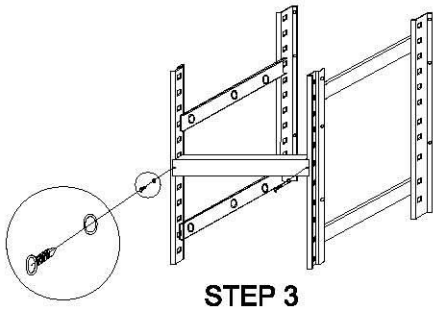
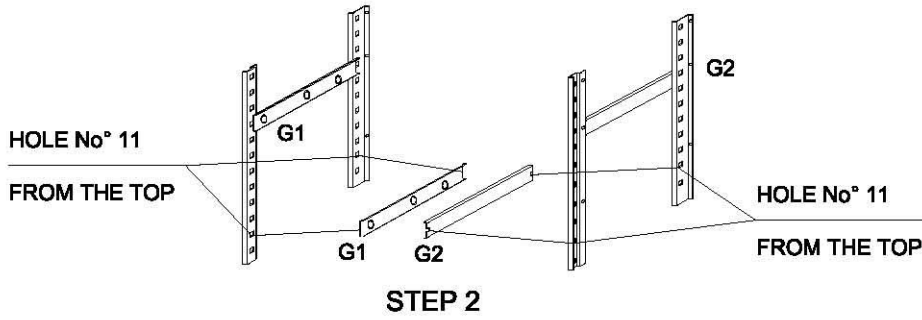
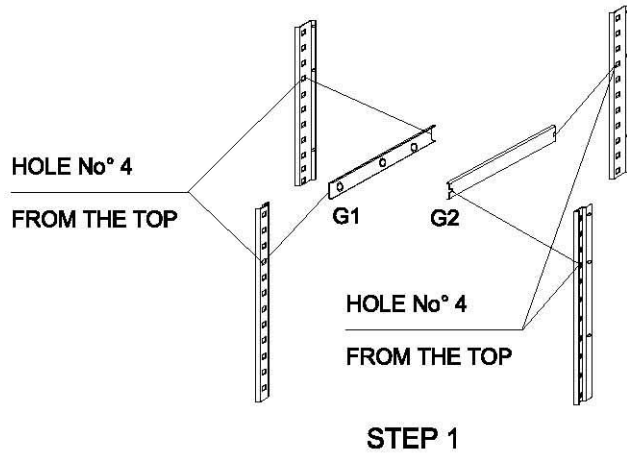
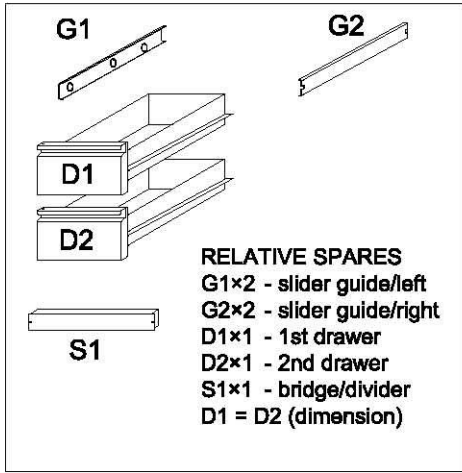

# SET 2 DRAWER ASSEMBLY GUIDE - 1/3+2/3

**G1**      **G2**

**D1**  
**D2**

**S1**

**RELATIVE SPARES**  
 G1×2 - slider guide/left  
 G2×2 - slider guide/right  
 D1×1 - 1st drawer  
 D2×1 - 2nd drawer  
 S1×1 - bridge/divider  
 D1 < D2 (dimension)

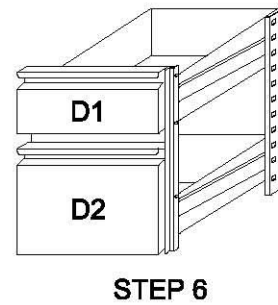
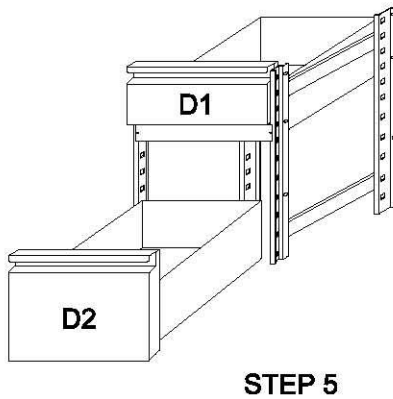
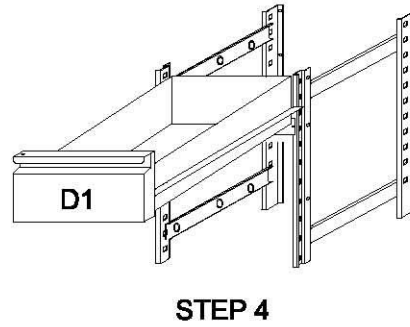
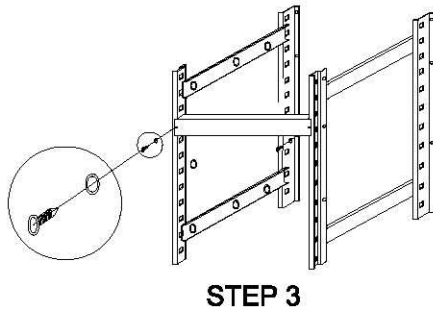
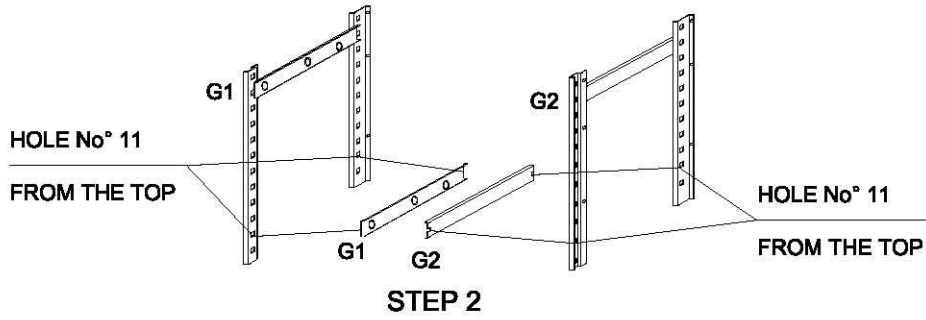
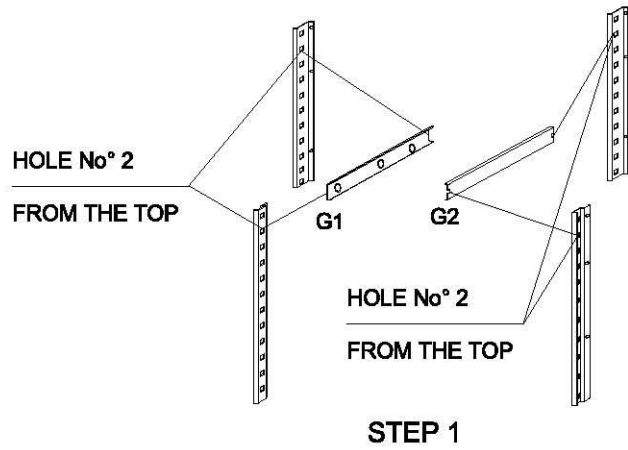

# SET 2 DRAWER ASSEMBLY GUIDE - 3x1/3

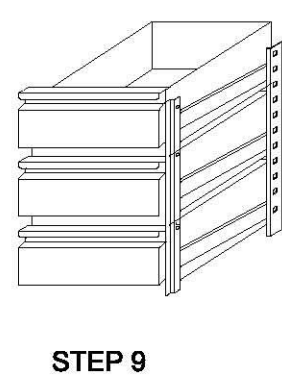
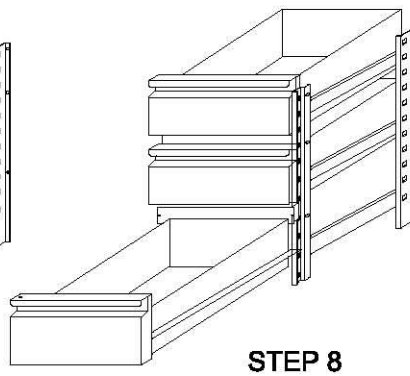
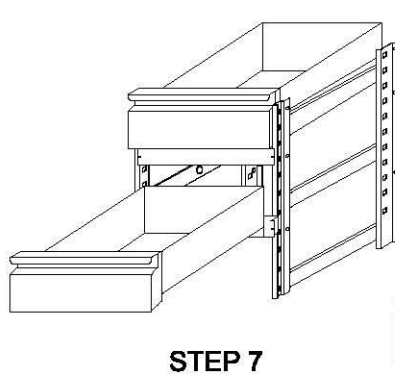
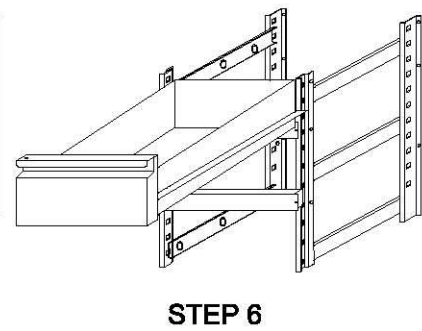
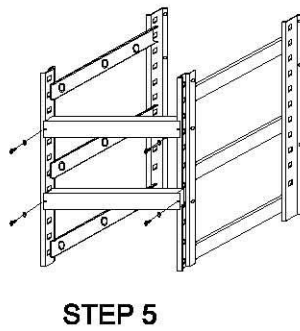
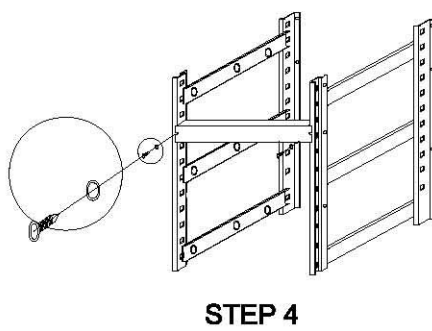
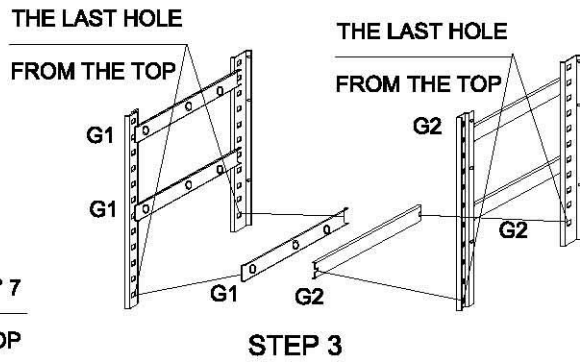
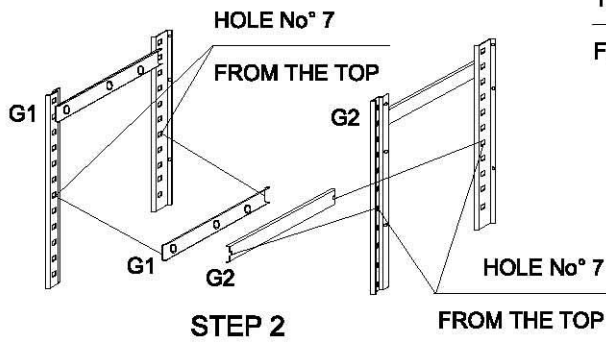
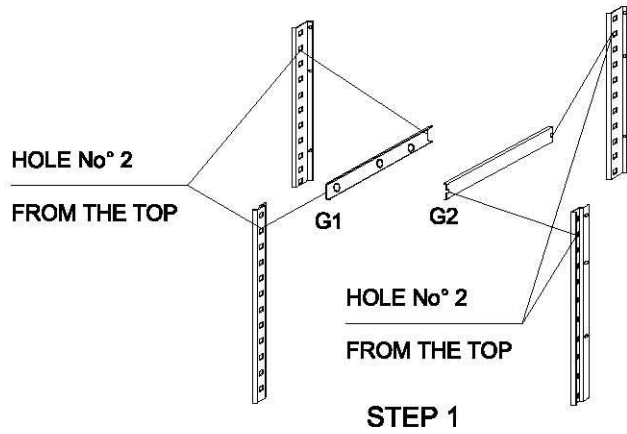
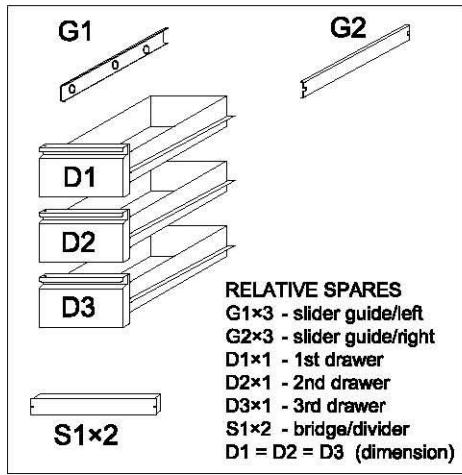

## UK Table of Contents

Safety Tips .....	1
Introduction .....	2
Pack Contents .....	2
Installation .....	2
Fitting the Shelves .....	2
Operation .....	2
Storing Food .....	2
Turn On .....	2
Manual Defrost .....	3
Cleaning, Care & Maintenance .....	3
Cleaning the Condenser .....	3
Troubleshooting .....	3
Technical Specifications .....	4
Electrical Wiring .....	6
Disposal .....	6
Compliance .....	6

## IT Indice

Suggerimenti per la sicurezza .....	8
Introduzione .....	8
Contenuto dell'imballaggio .....	8
Installazione .....	8
Montaggio dei ripiani .....	8
Funzionamento .....	8
Conservazione dei cibi .....	8
Accensione .....	8
Sbrinamento manuale .....	8
Pulizia e manutenzione .....	9
Pulizia del condensatore .....	9
Risoluzione dei problemi .....	9
Specifiche tecniche .....	10
Cablaggi elettrici .....	12
Smaltimento .....	12
Conformità .....	12

## ES Índice

Consejos de Seguridad .....	14
Introducción .....	14
Contenido del Conjunto .....	14
Instalación .....	14
Montaje de las protecciones .....	14
Funcionamiento .....	14
Almacenamiento de comida .....	14
Activación .....	14
Descongelación manual .....	14
Cuidado y mantenimiento .....	15
Limpieza del condensador .....	15
Resolución de problemas .....	15
Especificaciones Técnicas .....	16
Cableado Eléctrico .....	18
Desecho .....	18
Cumplimiento .....	18

## FR Sommaire

Conseils de sécurité .....	20
Introduction .....	20
Contenu de l'emballage .....	20
Installation .....	20
Installation des clayettes .....	20
Fonctionnement .....	20
Stockage des aliments .....	20
Mise en service .....	20
Décongélation manuelle .....	20
Nettoyage, entretien et maintenance .....	21
Nettoyage du condensateur .....	21
Dépannage .....	21
Spécifications techniques .....	22
Raccordement électrique .....	24
Mise au rebut .....	24
Conformité .....	25

## NL Inhoudsopgave

Veiligheidstips .....	26
Inleiding .....	26
Verpakkingsinhoud .....	26
Installatie .....	26
Het plaatsen van de lades .....	26
Bediening .....	26
Opslag van levensmiddelen .....	26
Inschakelen .....	26
Handmatig ontdooien .....	26
Reiniging, zorg & onderhoud .....	27
Reiniging van de condensor .....	27
Oplossen van problemen .....	27
Technische specificaties .....	28
Elektrische bedrading .....	30
Afvalverwerking .....	30
Product conformiteit .....	30

## DE Inhalt

Sicherheitshinweise .....	32
Einführung .....	32
Lieferumfang .....	32
Montage .....	32
Befestigen der Ablagen .....	32
Betrieb .....	32
Lagerung von Nahrungsmitteln .....	32
Einschalten .....	32
Manuelles Abtauen .....	32
Reinigung, Pflege und Wartung .....	33
Reinigen des Kondensators .....	33
Störungssuche .....	33
Technische spezifikationen .....	34
Elektroanschlüsse .....	36
Entsorgung .....	36
Konformität .....	36

## PT Índice

Conselhos de segurança .....	38
Introdução .....	38
Conteúdo da embalagem .....	38
Instalação .....	38
Colocar as prateleiras .....	38
Funcionamento .....	38
Armazenamento de produtos alimentares .....	38
Ligar .....	38
Descongelamento manual .....	38
Limpeza, cuidados & manutenção .....	39
Limpar o condensador .....	39
Resolução de problemas .....	39
Especificações técnicas .....	40
Cablagem elétrica .....	42
Tratamento de lixo e resíduos .....	42
Conformidade .....	42

## RUS Содержание

Меры предосторожности .....	44
Введение .....	44
Комплектация .....	44
Установка .....	44
Установка полок .....	44
Эксплуатация .....	44
Хранение продуктов .....	44
Включение .....	44
Принудительное размораживание .....	44
Содержание и техническое обслуживание, уход и очистка .....	45
Очищение конденсатора .....	45
Устранение неполадок .....	45
Технические спецификации .....	46
Электропроводка .....	48
Утилизация .....	49
Соответствие техническим требованиям .....	49

## İÇERİK

Guvenlik İpuçları.....	50
Giris.....	50
Ambalaj İÇeriĐi.....	50
Kurulum.....	50
Rafların Kurulumu.....	50
Operasyon.....	51
Gıdaların saklanması.....	51
Çalıřtırma.....	51
Manuel Defrost.....	51
Temizleme ve Bakım.....	51
Kondanser TemizliĐi.....	51
Azılar ve çözümleri.....	52
Teknik Özellikler.....	52
Elektrik Diyagramı.....	55
mha etme.....	55
Uyumluluk.....	55
Uyarılar.....	55

### **URETİCİ :**

#### **COLDERA IBERIA SL.**

Travessera Collblanc No12-16PI.LOCAL 08904

L'Hospitalet De Llobregat

BARCELONA SPAIN

[www.cold-era.es](http://www.cold-era.es)

[info@cold-era.es](mailto:info@cold-era.es)

### **ITHALATÇI :**

#### **COLDERA PAZARLAMA SAN VE TİC AŞ**

ATATÜRK MAHALLESİ KAVAK SOKAK NO:37

SOKE

AYDIN / TÜRKİYE

[www.cold-era.com](http://www.cold-era.com)

[info@cold-era.com](mailto:info@cold-era.com)

## Safety Tips

- Position on a flat, stable surface.
- A service agent/qualified technician should carry out installation and any repairs if required. Do not remove any components or service panels on this product.
- Consult Local and National Standards to comply with the following:
  - Health and Safety at Work Legislation
  - BS EN Codes of Practice
  - Fire Precautions
  - IEE Wiring Regulations
  - Building Regulations
- DO NOT use jet/pressure washers to clean the appliance.
- DO NOT use the appliance outside.
- DO NOT use this appliance to store medical supplies.
- DO NOT use electrical appliances inside the appliance (e.g. heaters, ice-cream makers etc.)
- DO NOT stand or support yourself on the base, drawers or doors.
- DO NOT allow oil or fat to come into contact with the plastic components or door seal. Clean immediately if contact occurs.
- Bottles that contain a high percentage of alcohol must be sealed and placed vertically in the refrigerator.
- Always carry, store and handle the appliance in a vertical position and move by holding the base of the appliance.
- Always switch off and disconnect the power supply to the unit before cleaning.
- Keep all packing away from children. Dispose of the packaging in accordance with the regulations of local authorities.
- If the power cord is damaged, it must be replaced by an agent or a recommended qualified technician in order to avoid a hazard.
- This unit can be used by children aged above 8 years and persons with reduced physical, sensory or mental capabilities or lacking of experience and knowledge who have been given supervision or using instruction of the device and understand the resulting risks (for European market).
- This appliance is not intended for use by persons (including children) with reduced physical, sensory or mental capabilities, or lack of experience and knowledge, unless they have been given supervision or instruction concerning use of the appliance by a person responsible for their safety (for market beyond European).
- Children should be supervised to ensure that they do not play with the appliance.
- Sound pressure level at workstation is far below 70dB.
- Maximum loading of each type of shelf: 20Kg.

## Introduction

Please take a few moments to carefully read through this manual. Correct maintenance and operation of this machine will provide the best possible performance from your product.

## Pack Contents

The following is included:

- Refrigerator or Freezer
- Shelf guides (2 per door)
- Shelves (1 per door)
- Instruction manual

We pride ourselves on quality and services, ensuring that at the time of packaging the contents are supplied fully functional and free of damage.

Should you find any damage as a result of transit, please contact your dealer immediately.

## Installation

**Φ Note: If the unit has not been stored or moved in an upright position, let it stand upright for approximately 12 hours before operation. If in doubt allow to stand.**

1. Remove the appliance from the packaging. Make sure that all protective plastic film and coatings are thoroughly removed from all surfaces.
2. Maintain a distance of 20cm (7 inches) between the unit and walls or other objects for ventilation. Increase this distance if the obstacle is a heat source.

**Φ Note: Before using the appliance for the first time, clean the shelves and interior with soapy water.**

3. Set the brakes on the castors to keep the appliance in position **OR**

Level the appliance by adjusting the screw feet.

## Fitting the Shelves

1. Place one set of shelf guides on either side of the cabinet at the desired height.
2. Slide the shelf into place.
3. Repeat for the remaining shelves.

**Φ Note: This is vital for ensuring correct drainage of condensation.**

## Operation

### Storing Food

To get the best results from your appliance, follow these instructions:

- Only store foodstuffs in the appliance when it has reached the correct operating temperature.
- Do not place uncovered hot food or liquid inside the appliance.
- Wrap or cover food where possible.
- Do not obstruct the fans inside the appliance.
- Avoid opening the doors for prolonged periods of time.

### Turn On

1. Close the door(s) of the appliance.
2. Ensure the power switch is set to [O] and turn on at the socket.

3. Switch on the Power [||]. The current temperature within the appliance is displayed.

## Manual Defrost

The appliance will automatically run a defrost cycle every six hours.

**Φ Note: The cycle starts from the time the appliance is initially powered up.**

To manually defrost the appliance:

1. Press and hold the DEFROST  button for 5 seconds.
2. The defrost cycle will start immediately and the Defrost LED illuminates. The defrost will last a maximum of 30 minutes.

**Φ Note: Starting a manual defrost also resets the manual defrost timer.**

3. The next automatic defrost will start six hours after the manual defrost has finished.

## Cleaning, Care & Maintenance

- Switch off and disconnect from the power supply before cleaning.
- Clean the interior of the appliance as often as possible.
- Do not use abrasive cleaning agents. These can leave harmful residues.
- Clean the door seal with water only.
- Always wipe dry after cleaning.
- Do not allow water used in cleaning to run through the drain hole into the evaporation pan.
- Take care when cleaning the rear of the appliance. Sharp edges can cut.
- An agent or qualified technician must carry out repairs if require.

## Cleaning the Condenser

Periodically cleaning the condenser can extend the life of the appliance.

We recommend that your agent or qualified technician clean the condenser

## Troubleshooting

If your appliance develops a fault, please check the following table before making a call to your retailer.

Fault	Probable Cause	Action
The appliance is not working	The unit is not switched on	Check the unit is plugged in correctly and switched on
	Plug and lead are damaged	Call your agent or qualified Technician
	Fuse in the plug has blown	Replace the fuse
	Power supply	Check power supply
	Internal wiring fault	Call your agent or qualified Technician
The appliance turns on, but the temperature is too high/low	Too much ice on the evaporator	Defrost the appliance
	Condenser blocked with dust	Call your agent or qualified Technician
	Doors are not shut properly	Check doors are shut and seals are not damaged
	Appliance is located near a heat source or air flow to the condenser is being interrupted	Move the refrigerator to a more suitable location
	Ambient temperature is too high	Increase ventilation or move appliance to a cooler position
	Unsuitable foodstuffs are being stored in the appliance	Remove any excessive hot foodstuffs or blockages to the fan
The appliance is leaking water	Appliance is overloaded	Reduce the amount of food stored in the appliance
	The appliance is not properly leveled	Adjust the screw feet to level the appliance (if applicable)
	The discharge outlet is blocked	Clean the discharge outlet
	Movement of water to the drain is obstructed	Clean the floor of the appliance ( if applicable)
	The water container is damaged	Call your agent or qualified Technician
The drip tray is overflowing	Empty the drip tray (if applicable)	

Fault	Probable Cause	Action
The appliance is unusually loud	Loose nut/screw	Check and tighten all nuts and screws
	The appliance has not been installed in a level or stable position	Check installation position and change if necessary

### Technical Specifications(Other details see insert) (R290)

Model	Voltage	Current	Temperature Range	Capacity (liters)	Dimensions H×W×D (mm)	Weight (Kg)
GN2100BT	220-240V 50Hz	3.0A	-10°C ~ -20°C	314 Vn:206	1360×700×860	97
GN3100BT	220-240V 50Hz	3.0A	-10°C ~ -20°C	465 Vn:309	1795×700×860	117
GN4100BT	220-240V 50Hz	4.0A	-10°C ~ -20°C	616 Vn:412	2230×700×860	146
GN2200BT	220-240V 50Hz	3.0A	-10°C ~ -20°C	314 Vn:206	1360×700×960	103
GN3200BT	220-240V 50Hz	3.0A	-10°C ~ -20°C	465	1795×700×960	130
GN4200BT	220-240V 50Hz	4.0A	-10°C ~ -20°C	616	2230×700×960	160
SNACK2100BT	220-240V 50Hz	3.0A	-10°C ~ -20°C	260	1360×600×860	86
SNACK3100BT	220-240V 50Hz	3.0A	-10°C ~ -20°C	386	1795×600×860	107
SNACK4100BT	220-240V 50Hz	4.0A	-10°C ~ -20°C	511	2230×600×860	133
SNAC2200BT	220-240V 50Hz	3.0A	-10°C ~ -20°C	260	1360×600×960	99
SNACK3200BT	220-240V 50Hz	3.0A	-10°C ~ -20°C	386	1795×600×960	120
SNACK4200BT	220-240V 50Hz	4.0A	-10°C ~ -20°C	511	2230×600×960	147
UGN2100TN	220-240V 50Hz	1.2A	+2°C ~ +8°C	314	1360×700×650	93
UGN3100TN	220-240V 50Hz	1.2A	+2°C ~ +8°C	317	1795X700X650	104
UGN4100TN	220-240V 50Hz	1.2A	+2°C ~ +8°C	420	2230×700×650	125
GN2200TNG	220-240V 50Hz	1.2A	+2°C ~ +8°C	314	1360×700×960	100
GN3100TNG	220-240V 50Hz	1.2A	-2°C ~ +8°C	465	1795×700×860	114
GN3100TNG	220-240V 50Hz	1.2A	+2°C ~ +8°C	465	1795×700×860	126
GN3200TN	220-240V 50Hz	1.2A	-2°C ~ +8°C	465	1795×700×960	125

Model	Voltage	Current	Temperature Range	Capacity (liters)	Dimensions H×W×D (mm)	Weight (Kg)
GN3200TNG	220-240V 50Hz	1.2A	+2°C ~ +8°C	465	1795×700×960	137
GN4100TN	220-240V 50Hz	1.3A	-2°C ~ +8°C	616 Vn:412	2230×700×860	138
GN4100TNG	220-240V 50Hz	1.3A	+2°C ~ +8°C	616	2230×700×860	150
GN4200TN	220-240V 50Hz	1.3A	-2°C ~ +8°C	616 Vn:412	2230×700×960	152
GN4200TNG	220-240V 50Hz	1.3A	+2°C ~ +8°C	616	2230×700×960	164
PA2100TN	220-240V 50Hz	1.2A	+2°C ~ +8°C	428 Vn:304	1510×800×860	105
PA2200TN	220-240V 50Hz	1.2A	+2°C ~ +8°C	428 Vn:304	1510×800×960	116
PA3100TN	220-240V 50Hz	1.3A	+2°C ~ +8°C	635 Vn:456	2020×800×860	132
PA3200TN	220-240V 50Hz	1.3A	+2°C ~ +8°C	635 Vn:456	2020×800×960	146
SNACK2100TN	220-240V 50Hz	1.2A	-2°C ~ +8°C	260 Vn:172	1360×600×860	81
SNACK2100TNG	220-240V 50Hz	1.2A	+2°C ~ +8°C	260	1360×600×860	95
SNACK2200TN	220-240V 50Hz	1.2A	-2°C ~ +8°C	260 Vn:172	1360×600×960	94
SNACK2200TNG	220-240V 50Hz	1.2A	+2°C ~ +8°C	260	1360×600×960	108
SNACK3100TN	220-240V 50Hz	1.2A	-2°C ~ +8°C	386 Vn:258	1795×600×860	102
SNACK3100TNG	220-240V 50Hz	1.2A	+2°C ~ +8°C	386	1795×600×860	116
SNACK3200TN	220-240V 50Hz	1.2A	-2°C ~ +8°C	386 Vn:258	1795×600×960	115
SNACK3200TNG	220-240V 50Hz	1.2A	+2°C ~ +8°C	386	1795×600×960	129
SNACK4100TN	220-240V 50Hz	1.3A	-2°C ~ +8°C	511 Vn:344	2230×600×860	126
SNACK4100TNG	220-240V 50Hz	1.3A	+2°C ~ +8°C	511	2230×600×860	130
SNACK4200TN	220-240V 50Hz	1.3A	-2°C ~ +8°C	511 Vn:344	2230×600×960	140
SNACK4200TNG	220-240V 50Hz	1.3A	+2°C ~ +8°C	511	2230×600×960	155
U-GN2100TN	220-240V 50Hz	1.2A	-2°C ~ +8°C	214 Vn:130	1360×700×650	80
U-GN2140TN	220-240V 50Hz	1.2A	-2°C ~ +8°C	214 Vn:130	1360×700×650	93
U-GN3100TN	220-240V 50Hz	1.2A	-2°C ~ +8°C	317 Vn:195	1795×700×650	104
U-GN3160TN	220-240V 50Hz	1.2A	-2°C ~ +8°C	317 Vn:195	1795×700×650	123

Model	Voltage	Current	Temperature Range	Capacity (liters)	Dimensions H×W×D (mm)	Weight (Kg)
U-GN4100TN	220-240V 50Hz	1.3A	-2°C ~ +8°C	420 Vn:260	2230×700×650	125
U-GN4180TN	220-240V 50Hz	1.3A	-2°C ~ +8°C	420 Vn:260	2230×700×650	150
SH2000/700	220-240V 50Hz	1.3A	+2°C ~ +8°C	396	1360×700×1085	100
SH2000/800	220-240V 50Hz	1.3A	+2°C ~ +8°C	459	1510×800×1085	115
SH3000/700	220-240V 50Hz	1.3A	+2°C ~ +8°C	470	1795×700×1085	121
SH3000/800	220-240V 50Hz	1.3A	+2°C ~ +8°C	576	2020×800×1085	145
PZ1610TN	220-240V 50Hz	1.2A	+2°C ~ +8°C	221	1515×800×1000	256
PZ2600TN	220-240V 50Hz	1.2A	+2°C ~ +8°C	428 Vn:304	1510×800×1000	234
PH2610TN	220-240V 50Hz	1.2A	+2°C ~ +8°C	428 Vn:304	2025×800×1000	334
PZ3600TN	220-240V 50Hz	1.3A	+2°C ~ +8°C	635 Vn:456	2025×800×1000	294

## Electrical Wiring

Appliances are supplied with a 3 pin, moulded, BS1363 plug and lead, with a 13 amp fuse as standard. The plug is to be connected to a suitable mains socket. Appliances are wired as follows:

- Live wire (coloured brown) to terminal marked **L**
- Neutral wire (coloured blue) to terminal marked **N**
- Earth wire (coloured green/yellow) to terminal marked **E**

All appliances must be earthed, using a dedicated earthing circuit. If in doubt consult a qualified electrician.

Electrical isolation points must be kept clear of any obstructions. In the event of any emergency disconnection being required they must be readily accessible.

## Disposal

EU regulations require refrigeration product to be disposed of by specialist companies who remove or recycle all gasses, metal and plastic components.

Consult your local waste collection authority regarding disposal of your appliance. Local authorities are not obliged to dispose of commercial refrigeration equipment but may be able to offer advice on how to dispose of the equipment locally.

## Compliance

Parts have undergone strict product testing in order to comply with regulatory standards and specifications set by international, independent, and federal authorities.

Products have been approved to carry the following symbol.

**The R600a and R290 refrigerant used by this refrigerator**



**WARNING:**

Keep ventilation openings, in the appliance enclosure or in the built-in structure, clear of obstruction. Do not use mechanical devices or other means to accelerate the defrosting process, other than those recommended by the manufacturer.

Do not damage the refrigerant circuit.

Do not use electrical appliances inside the food storage compartments of the appliance, unless they are of the type recommended by the manufacturer.



IN CASE THE SUPPLY CABLE IS DAMAGED, THE MANUFACTURER OF THE AFTER-SALES SERVICE, OR QUALIFIED TECHNICIAN SHALL REPLACE IT. IN ORDER TO PREVENT ANY POSSIBLE RISK.

THE LAMP REPAIR AND REPLACEMENT SHALL BE CARRIED OUT BY QUALIFIED TECHNICIANS, WITH POWER SUPPLY DISCONNECTED. REPLACE WITH IDENTICAL LAMPS.

ONLY QUALIFIED TECHNICIANS SHALL CARRY OUT THE EXTRAORDINARY MAINTENANCE INTERVENTIONS.

**Disposal of packaging**

All packaging materials should be disposed of in an environmentally friendly way.

The cardboard may be used as scrap paper. The protective foil and the foam cushions are CFC-free.

Do not allow children to play with the packaging and destroy plastic bags safely.

You can break or cut the cardboard into smaller pieces and give to a waste paper disposal service.

**Environmental protection**

Discarded electric appliances are recyclable and should not be discarded in the domestic waste!

Please actively support us in conserving resources and protecting the environment by returning this appliance to the collection centres (if available).

## Suggerimenti per la sicurezza

- Posizionare il fabbricatore di ghiaccio su una superficie in piano e stabile
- L'installazione e le eventuali riparazioni devono venire eseguite da un agente/tecnico qualificato. Non rimuovere i componenti o i pannelli di accesso dell'apparecchio.
- Verificare la conformità alle normative locali e nazionali di quanto segue:
  - Normativa antinfortunistica sul lavoro
  - Linee guida BS EN
  - Precauzioni antincendio
  - Normativa IEE sui circuiti elettrici
  - Norme di installazione
- NON utilizzare sistemi di lavaggio a getto o pressione per pulire l'apparecchio.
- NON utilizzare l'apparecchio per conservare presidi medico-sanitari.
- NON utilizzare apparecchiature elettriche all'interno dell'apparecchio (ad esempio, gelatiere, ecc..).
- NON stare in piedi o in altro sostenersi alla base, ai cassetti o ai portelli.
- NON mettere a contatto olio o grassi con i componenti in plastica o con la guarnizione dei portelli. Pulire immediatamente in caso di contatto.
- Per esclusivo uso in ambienti chiusi.
- Le bottiglie contenenti una elevata percentuale di alcool devono venire sigillate e posizionate verticalmente nel frigorifero.
- Trasportare, immagazzinare e movimentare l'apparecchio sempre in posizione verticale e spostarlo mantenendone la base.
- Spegnerne e disconnettere l'alimentazione dell'unità prima di pulirla.
- Tenere lontano l'imballaggio dalla portata dei bambini. Smaltire l'imballaggio in conformità alle normative locali.
- Se danneggiato, il cavo di alimentazione deve venire sostituito da un agente o da un tecnico qualificato al fine di prevenire eventuali rischi.

## Introduzione

Leggere con attenzione il presente manuale. La manutenzione e l'utilizzo corretti di questo apparecchio consentiranno di ottenere le massime prestazioni da questo prodotto.

## Contenuto dell'imballaggio

- L'imballaggio contiene quanto segue
- Frigorifero o congelatore
- Guide per ripiani (2 per portello)
- Ripiani (1 per portello)
- Manuale di istruzioni

Garantisce una qualità e un servizio impeccabili e assicura che al momento dell'imballaggio tutti i componenti forniti sono integralmente funzionanti e privi di difetti. Nel caso siano rilevati danni risultanti dal trasporto del prodotto, rivolgersi immediatamente al rivenditore locale.

## Installazione

**Φ Nota: se l'apparecchio è stato immagazzinato o spostato in posizione non verticale, lasciarlo in posizione verticale per circa 12 ore prima di metterlo in funzione. In caso di dubbio, osservare comunque questa precauzione.**

1. Rimuovere l'apparecchio dall'imballaggio. Assicurarsi che la pellicola protettiva e rivestimenti in plastica siano interamente rimossi da tutte le superfici.
2. Osservare una distanza di 20 cm tra l'unità e le pareti o altri oggetti al fine di assicurare la necessaria ventilazione. Aumentare questa distanza se in prossimità di una sorgente di calore.

**Φ Nota: prima di utilizzare l'apparecchio per la prima volta, pulire i ripiani e l'interno dell'apparecchio con acqua saponata.**

3. Innestare i freni delle ruote a sfera per mantenere l'apparecchio in posizione **OPPURE** Mettere in piano l'apparecchio regolando i piedi.

## Montaggio dei ripiani

1. Posizionare un set di guide su ogni lato dell'armadio all'altezza desiderata.
2. Fare scivolare in posizione il ripiano.
3. Ripetere l'operazione per i ripiani rimanenti.

**Φ Nota: il corretto montaggio è essenziale perché la condensa possa essere correttamente scaricata.**

## Funzionamento

### Conservazione dei cibi

Per ottenere i migliori risultati dall'apparecchio, osservare le seguenti istruzioni:

- Conservare i cibi nell'apparecchio solo quando esso ha raggiunto la corretta temperatura di esercizio.
- Non conservare cibi o liquidi bollenti scoperti all'interno dell'apparecchio.
- Se possibile, avvolgere o coprire i cibi.
- Non ostruire le ventole all'interno dell'apparecchio.
- Evitare di aprire i portelli per periodi prolungati di tempo.

### Accensione

1. Chiudere i portelli dell'apparecchiatura.
2. Assicurarsi che l'interruttore dell'alimentazione sia impostato su [O] e acceso alla presa.
3. Accendere l'alimentazione [I]. Viene visualizzata la temperatura corrente all'interno dell'apparecchiatura.

### Sbrinamento manuale

L'apparecchio esegue automaticamente un ciclo di sbrinamento ogni sei ore.

**Φ Nota: il ciclo inizia dall'ora in cui l'apparecchio viene collegato per la prima volta all'alimentazione elettrica.**

Per sbrinare manualmente l'apparecchio:

1. Premere senza rilasciare il pulsante SBRINAMENTO  per 5 secondi.
2. Il ciclo di sbrinamento inizia immediatamente e la spia di sbrinamento si accende. Lo sbrinamento ha una durata massima di 30 minuti.

**Φ Nota: l'avvio dello sbrinamento manuale reimposta anche il timer di sbrinamento automatico. Il successivo sbrinamento automatico inizierà sei ore dopo la conclusione dello sbrinamento manuale.**

3. L'acqua reflua viene raccolta nella vaschetta dell'acqua reflua.

## Pulizia e manutenzione

- Prima di eseguire la pulizia, spegnere e scollegare l'alimentazione.
- Pulire l'interno dell'apparecchio quanto più spesso possibile.
- Non utilizzare detergenti abrasivi in quanto possono lasciare residui nocivi.
- Pulire la guarnizione di tenuta dei portelli solo con acqua.
- Asciugare sempre dopo la pulizia.
- Non permettere che l'acqua utilizzata per la pulizia pene tri attraverso il foro di scarico nella casca di evaporazione.
- Prestare attenzione durante la pulizia della parte posteriore dell'apparecchio. Gli attrezzi con bordi taglienti possono provocare tagli.
- Le riparazioni devono venire eseguite da un tecnico qualificato o da un agente.

## Pulizia del condensatore

La pulizia periodica del condensatore consente di prolungare il ciclo di vita dell'apparecchio. La pulizia del condensatore deve venire eseguita da un tecnico qualificato o da un agente.

## Risoluzione dei problemi

Se dovessero verificarsi guasti dell'apparecchio, controllare la tabella seguente prima di contattare il rivenditore.

Guasto	Probabile causa	Azione
L'apparecchio non funziona	L'apparecchio non è acceso	Controllare che l'apparecchio sia correttamente collegato e acceso
	La presa e il cavo sono danneggiati	Rivolgersi a un tecnico qualificato o a un agente
	Il fusibile della presa è guasto	Sostituire il fusibile della presa
	Alimentazione	Controllare l'alimentazione
	Guasto dei circuiti interni	Rivolgersi a un tecnico qualificato o a un agente
L'apparecchio si accende ma la temperatura è troppo alta o troppo bassa	Quantità eccessiva di ghiaccio nel evaporatore	Sbrinare l'apparecchio
	Il condensatore è bloccato dalla polvere	Rivolgersi a un tecnico qualificato o a un agente
	I portelli non sono chiusi in maniera appropriata	Contro che i portelli siano chiusi e che le guarnizioni di tenuta non siano danneggiate
	L'apparecchio è posizionato in prossimità di una sorgente di calore oppure il flusso di aria al condensatore è interrotto	Spostare il frigorifero in una posizione più appropriata
	La temperatura ambientale è troppo alta	Aumentare la ventilazione oppure spostare l'apparecchio in una posizione più fresca
	Sono stati conservati nell'apparecchio cibi non appropriati	Rimuovere i cibi eccessivamente caldi o le ostruzioni della ventola
	L'apparecchio è sovraccarico	Ridurre la quantità dei cibi presenti nell'apparecchio
L'apparecchio perde acqua	L'apparecchio non è in posizione piana	Regolare i piedi al fine di mantenere in piano l'apparecchio (se pertinente)
	La bocca di scarico è bloccate	Pulire la bocca di scarico
	Il movimento dell'acqua verso lo scarico è ostruito	Pulire il pavimento dell'apparecchio (se pertinente)
	Il contenitore dell'acqua è danneggiato	Rivolgersi a un tecnico qualificato o a un agente
	La vaschetta di raccolta dell'acqua di sbrinamento è troppo piena	Svuotare la vaschetta di raccolta dell'acqua di sbrinamento (se pertinente)

Guasto	Probabile causa	Azione
L'apparecchio presenta una rumorosità eccessiva	La fascia di sicurezza non è stata rimossa	Rimuovere la fascia di sicurezza
	Dadi o citi allentati	Controllare e serrare tutti i dadi e le citi

### Specifiche tecniche(Altri dettagli vedi inserto) (R290)

Modello	Tensione	Corrente	Intervallo di temperatura	Capacità (litri)	Dimensioni h×l×p (mm)	Peso (Kg)
GN2100BT	220-240V 50Hz	3.0A	-10°C ~ -20°C	314 Vn:206	1360×700×860	97
GN3100BT	220-240V 50Hz	3.0A	-10°C ~ -20°C	465 Vn:309	1795×700×860	117
GN4100BT	220-240V 50Hz	4.0A	-10°C ~ -20°C	616 Vn:412	2230×700×860	146
GN2200BT	220-240V 50Hz	3.0A	-10°C ~ -20°C	314 Vn:206	1360×700×960	103
GN3200BT	220-240V 50Hz	3.0A	-10°C ~ -20°C	465 Vn:309	1795×700×960	130
GN4200BT	220-240V 50Hz	4.0A	-10°C ~ -20°C	616 Vn:412	2230×700×960	160
SNACK2100BT	220-240V 50Hz	3.0A	-10°C ~ -20°C	260 Vn:172	1360×600×860	86
SNACK3100BT	220-240V 50Hz	3.0A	-10°C ~ -20°C	386	1795×600×860	107
SNACK4100BT	220-240V 50Hz	4.0A	-10°C ~ -20°C	511 Vn:344	2230×600×860	133
SNAC2200BT	220-240V 50Hz	3.0A	-10°C ~ -20°C	260 Vn:172	1360×600×960	99
SNACK3200BT	220-240V 50Hz	3.0A	-10°C ~ -20°C	386 Vn:258	1795×600×960	120
SNACK4200BT	220-240V 50Hz	4.0A	-10°C ~ -20°C	511 Vn:344	2230×600×960	147
GN2100TN	220-240V 50Hz	1.2A	-2°C ~ +8°C	314 Vn:206	1360×700×860	93
GN2100TNG	220-240V 50Hz	1.2A	+2°C ~ +8°C	314	1360×700×860	98
GN2200TN	220-240V 50Hz	1.2A	-2°C ~ +8°C	314 Vn:206	1360×700×960	95
GN2200TNG	220-240V 50Hz	1.2A	+2°C ~ +8°C	314	1360×700×960	100
GN3100TN	220-240V 50Hz	1.2A	-2°C ~ +8°C	465 Vn:309	1795×700×860	114
GN3100TNG	220-240V 50Hz	1.2A	+2°C ~ +8°C	465	1795×700×860	126
GN3200TN	220-240V 50Hz	1.2A	-2°C ~ +8°C	465	1795×700×960	125

Modello	Tensione	Corrente	Intervallo di temperatura	Capacità (litri)	Dimensioni l x l x p (mm)	Peso (Kg)
GN3200TNG	220-240V 50Hz	1.2A	+2°C ~ +8°C	465	1795×700×960	137
GN4100TN	220-240V 50Hz	1.3A	-2°C ~ +8°C	616 Vn:412	2230×700×860	138
GN4100TNG	220-240V 50Hz	1.3A	+2°C ~ +8°C	616	2230×700×860	150
GN4200TN	220-240V 50Hz	1.3A	-2°C ~ +8°C	616 Vn:412	2230×700×960	152
GN4200TNG	220-240V 50Hz	1.3A	+2°C ~ +8°C	616	2230×700×960	164
PA2100TN	220-240V 50Hz	1.2A	+2°C ~ +8°C	428 Vn:304	1510×800×860	105
PA2200TN	220-240V 50Hz	1.2A	+2°C ~ +8°C	428 Vn:304	1510×800×960	116
PA3100TN	220-240V 50Hz	1.3A	+2°C ~ +8°C	635 Vn:456	2020×800×860	132
PA3200TN	220-240V 50Hz	1.3A	+2°C ~ +8°C	635	2020×800×960	146
SNACK2100TN	220-240V 50Hz	1.2A	-2°C ~ +8°C	260 Vn:172	1360×600×860	81
SNACK2100TNG	220-240V 50Hz	1.2A	+2°C ~ +8°C	260	1360×600×860	95
SNACK2200TN	220-240V 50Hz	1.2A	-2°C ~ +8°C	260	1360×600×960	94
SNACK2200TNG	220-240V 50Hz	1.2A	+2°C ~ +8°C	260	1360×600×960	108
SNACK3100TN	220-240V 50Hz	1.2A	-2°C ~ +8°C	386 Vn:258	1795×600×860	102
SNACK3100TNG	220-240V 50Hz	1.2A	+2°C ~ +8°C	386	1795×600×860	116
SNACK3200TN	220-240V 50Hz	1.2A	-2°C ~ +8°C	386 Vn:258	1795×600×960	115
SNACK3200TNG	220-240V 50Hz	1.2A	+2°C ~ +8°C	386	1795×600×960	129
SNACK4100TN	220-240V 50Hz	1.3A	-2°C ~ +8°C	511 Vn:344	2230×600×860	126
SNACK4100TNG	220-240V 50Hz	1.3A	+2°C ~ +8°C	511	2230×600×860	130
SNACK4200TN	220-240V 50Hz	1.3A	-2°C ~ +8°C	511	2230×600×960	140
SNACK4200TNG	220-240V 50Hz	1.3A	+2°C ~ +8°C	511	2230×600×960	155
U-GN2100TN	220-240V 50Hz	1.2A	-2°C ~ +8°C	214 Vn:130	1360×700×650	80
U-GN2140TN	220-240V 50Hz	1.2A	-2°C ~ +8°C	214	1360×700×650	93

Modello	Tensione	Corrente	Intervallo di temperatura	Capacità (litri)	Dimensioni h×l×p (mm)	Peso (Kg)
U-GN3100TN	220-240V 50Hz	1.2A	-2°C ~ +8°C	317 Vn:195	1795×700×650	104
U-GN3160TN	220-240V 50Hz	1.2A	-2°C ~ +8°C	317 Vn:195	1795×700×650	123
U-GN4100TN	220-240V 50Hz	1.3A	-2°C ~ +8°C	420 Vn:260	2230×700×650	125
U-GN4180TN	220-240V 50Hz	1.3A	-2°C ~ +8°C	420 Vn:260	2230×700×650	150
SH2000/700	220-240V 50Hz	1.3A	+2°C ~ +8°C	396	1360×700×1085	100
SH2000/800	220-240V 50Hz	1.3A	+2°C ~ +8°C	459	1510×800×1085	115
SH3000/700	220-240V 50Hz	1.3A	+2°C ~ +8°C	470	1795×700×1085	121
SH3000/800	220-240V 50Hz	1.3A	+2°C ~ +8°C	576	2020×800×1085	145
PZ1610TN	220-240V 50Hz	1.2A	+2°C ~ +8°C	221	1515×800×1000	256
PZ2600TN	220-240V 50Hz	1.2A	+2°C ~ +8°C	428 Vn:304	1510×800×1000	234
PH2610TN	220-240V 50Hz	1.2A	+2°C ~ +8°C	428 Vn:304	2025×800×1000	334
PZ3600TN	220-240V 50Hz	1.3A	+2°C ~ +8°C	635 Vn:456	2025×800×1000	294

## Cablaggi elettrici

La spina deve venire collegata a una presa di rete appropriata. L'apparecchio ha i seguenti cablaggi:

- Filo sotto tensione (colore marrone) a terminale **L**
- Filo del neutro (colore blu) a terminale **N**
- Filo di terra (colore verde/giallo) a terminale **E**

L'apparecchio deve avere un circuito dedicato di messa a terra. In caso di dubbi, consultare un elettricista qualificato.

I punti di isolamento elettrico devono essere liberi da ostruzioni. In caso di emergenza, i punti devono essere facilmente raggiungibili qualora sia necessario scollegarli.

## Smaltimento

Le normative UE prevedono che lo smaltimento dei prodotti di refrigerazione sia eseguito da aziende specializzate nella rimozione o nel riciclaggio di tutti i gas e dei componenti in metallo e plastica.

Rivolgersi all'ente locale incaricato per informazioni sullo smaltimento di questo apparecchio. Gli enti locali non hanno l'obbligo di procedere allo smaltimento di apparecchi di refrigerazione commerciali ma sono in grado di fornire suggerimenti sulla modalità di smaltimento di tali apparecchi.

## Conformità

I componenti sono stati sottoposti a un rigoroso collaudo ai fini della conformità agli standard e alle specifiche normative previste dalle autorità internazionali, indipendenti e federali.

I prodotti sono stati autorizzati a esporre il seguente simbolo.

**R600a e R290 vengono utilizzati da questo frigorifero.**



### ATTENZIONE:

Alloggiamento o struttura integrata dell'apparecchiatura deve essere mantenuta libera per evitare l'intasamento delle aperture.

Oltre alle raccomandazioni del produttore, ma non con mezzi meccanici o altri mezzi per accelerare il processo di sbrinamento.

Non danneggiare il circuito refrigerante.

Non utilizzare apparecchi elettrici nella stanza di conservazione degli alimenti delle apparecchiature, a meno che non è raccomandato dal tipo di produttore.



NEL CASO IL CAVO DI ALIMENTAZIONE È DANNEGGIATO. IL CAVO DI ALIMENTAZIONE È 'DIMENTICATO. IL PRODUTTORE O IL SERVIZIO DI AFTER-SALES, O IL TECNICO QUALIFICATO, SOSTITUIRE. PER EVITARE QUALSIASI POSSIBILE RISCHIO.

LA RIPARAZIONE E LA SOSTITUZIONE DEI LAMPADARI SONO EFFETTUATI DA TECNICI QUALIFICATI, CON ALIMENTAZIONE DISCONNESSATA. SOSTITUIRE CON LAMPADAE IDENTICHE.

SOLO TECNICI QUALIFICATI VERRANNO LE INTERVENTI DI MANTENIMENTO EXTRAORDINARIO.

Smaltimento degli imballaggi

Tutti i materiali di imballaggio devono essere smaltiti in modo ecologico.

Il cartone può essere utilizzato come carta da rotta. La pellicola protettiva e i cuscini in schiuma sono privi di CFC.

Non permettere ai bambini di giocare con l'imballaggio e distruggere i sacchetti di plastica in modo sicuro.

È possibile rompere o tagliare il cartone in pezzi più piccoli e dare a un servizio di smaltimento cartaceo.

Protezione ambientale

Gli apparecchi elettrici scartati sono riciclabili e non devono essere scartati nei rifiuti domestici!

Forniamoci attivamente per conservare le risorse e proteggere l'ambiente, restituendo questo apparecchio ai centri di raccolta (se disponibili).



CE

## Consejos de Seguridad

- Colóquela sobre una superficie plana y estable
- Un técnico calificado deberá llevar a cabo la instalación y cualquier reparación en caso necesario. No retire el panel de este producto así como ningún componente.
- Consulte las Normas Locales y Nacionales correspondientes a lo siguiente:
- Legislación de Seguridad e Higiene en el Trabajo
  - Códigos de Práctica BS EN
  - Precauciones contra incendios
  - Normas de Cableado de la IEE
  - Normas de Construcción
- NO utilice dispositivos de lavado a chorro / presión para limpiar el aparato.
- NO utilice este aparato para almacenar existencias médicas.
- NO utilice aparatos eléctricos en el interior del aparato (por ejemplo, calentadores, máquinas de fabricación helados, etc.).
- NO se pare sobre la base, los cajones o las puertas ni se apoye en ellas.
- NO deje que el aceite o la grasa entren en contacto con los componentes de plástico o la unión de la puerta. Limpie el aparato inmediatamente si se produce contacto.
- Únicamente adecuado para uso en interiores.
- Las botellas que contienen un alto porcentaje de alcohol deben sellarse y colocarse verticalmente en el frigorífico
- Siempre se debe transportar, almacenar y manipular el aparato verticalmente y moverlo cogiéndolo de la base.
- Desconecte la máquina y desenchúfela del suministro eléctrico antes de llevar a cabo la limpieza.
- Mantenga el embalaje lejos del alcance de los niños. Deshágase del embalaje de acuerdo con las normas de las autoridades locales.
- Si el cable eléctrico está dañado, debe ser reemplazado por un técnico calificado recomendado para evitar cualquier riesgo.

## Introducción

Tómese unos minutos para leer este manual. El correcto mantenimiento y manejo de esta máquina proporcionará el mejor funcionamiento posible de su producto.

## Contenido del Conjunto

Se incluye lo siguiente:

- Frigorífico o Congelador
- Guías de estante (2 por puerta)
- Estantes (1 por puerta)
- Manual de instrucciones

Nos enorgullecemos del servicio y calidad y aseguramos que en el momento de empaquetar, el contenido se suministró con plena funcionalidad y sin ningún defecto. Si encontrara algún daño resultante del transporte, póngase en contacto inmediatamente con su distribuidor.

## Instalación

**Φ Nota:** Si el aparato no se ha almacenado o

transportado en posición vertical, déjelo en posición vertical durante aproximadamente 12 horas antes del funcionamiento. Si tiene alguna duda, deje el aparato en posición vertical.

1. Desembale el aparato. Asegúrese de que todos los revestimientos y las láminas de plástico de protección se hayan quitado totalmente de todas las superficies.
2. Mantenga una distancia de 20 cm (7 pulgadas) entre la unidad y las paredes u otros objetos para ventilación. Aumente la distancia si el obstáculo es una fuente de calor.

**Φ Nota:** antes de utilizar el aparato por primera vez, limpie los estantes y el interior con agua con jabón.

3. Coloque los frenos en las ruedecillas para mantener el aparato en su posición **O**  
Nivele el aparato ajustando la pata enroscada.

## Montaje de las protecciones

1. Coloque un juego de guías de estante a cada lado de la cabina a la altura deseada.
2. Deslice el estante hasta su lugar.
3. Repita el proceso con los estantes restantes.

**Φ Nota:** esto es vital para asegurar el desagüe completo de la condensación.

## Funcionamiento

### Almacenamiento de comida

Para obtener los mejores resultados de su aparato, siga estas instrucciones:

- Guarde alimentos en el aparato sólo cuando haya alcanzado la temperatura de funcionamiento correcta.
- No ponga comida ni líquidos calientes calientes sin cubrir en el interior del aparato.
- Envuelva o cubra la comida siempre que sea posible.
- No obstruya los ventiladores en el interior del aparato.
- Evite la apertura de las puertas durante periodos de tiempo prolongados.

### Activación

1. Cierre la (s) puerta (s) del aparato.
2. Asegúrese de que el interruptor de activación esté ajustado en [O] y conéctelo a la toma.
3. Conecte la Alimentación [I]. Se muestra la temperatura actual en el aparato.

### Descongelación manual

El aparato llevará a cabo automáticamente un ciclo de descongelación cada seis horas.

**Φ Nota:** el empieza a partir del momento en que el aparato se pone en funcionamiento por primera vez.

Para descongelar manualmente el aparato:

1. pulse y mantenga pulsado el botón DEFROST  durante 5 segundos.
2. El ciclo de descongelación se iniciará inmediatamente y

el LED Defrost se iluminará. La descongelación durará un máximo de 30 minutos.

**Φ Nota: el inicio de una descongelación manual también reinicializa el temporizador de descongelación automática. La siguiente descongelación automática se iniciará seis horas después de que haya finalizado la descongelación manual.**

El agua residual se recoge en la bandeja de agua residual.

## Cuidado y mantenimiento

- Desconecte la máquina y desenchúfela de la toma eléctrica antes de llevar a cabo la limpieza.
- Limpie el interior del aparato con la mayor frecuencia posible.
- No utilice productos abrasivos de limpieza. Estos pueden dejar residuos nocivos.
- Limpie la unión de la puerta sólo con agua.
- Seque bien el aparato después de limpiarlo.
- No permita que el agua utilizada en la limpieza pase por el agujero de desagüe hacia el recipiente de evaporación.
- Tenga cuidado al limpiar la parte trasera del aparato. Los bordes afilados pueden cortar.
- Un técnico calificado debe llevar a cabo las reparaciones en case de precisarse.

## Limpieza del condensador

La limpieza periódica del condensador puede aumentar la duración del aparato.  
Se recomienda que un técnico calificado realice la limpieza del condensador.

## Resolución de problemas

Si su aparato falla, por favor compruebe la siguiente tabla antes de llamar a su distribuidor.

Fallo	Causa probable	Acción
El aparato no funciona	El aparato no está conectado	Compruebe que el aparato esté enchufado correctamente y conectado
	El enchufe y el cable están dañados	Llame a un técnico calificado para reemplazar el cable
	El fusible del enchufe se ha fundido	Cambie el fusible del enchufe
	Suministro eléctrico	Compruebe el suministro eléctrico
	Fallo del cableado interno	Llame a un técnico calificado para revisar el cableado
El aparato se activa, pero la temperatura es demasiado alta / baja	Demasiado hielo en el condensador	Descongele el aparato
	Condensador bloqueado con polvo	Llame a un técnico calificado para desbloquear el condensador
	Las puertas no están bien cerradas	Compruebe que las puertas estén cerradas y las ranuras no estén dañadas
	El aparato se encuentra cerca de una fuente de calor o el caudal de aire hacia el condensador está siendo interrumpido	Traslada el frigorífico a un lugar más adecuado
	La temperatura ambiente es demasiado alta	Aumente la ventilación o traslade el aparato a un lugar más fresco
	Se guardan alimentos no adecuados en el aparato	Retire cualquier exceso de alimentos calientes u obstrucciones del ventilador
	El aparato está sobrecargado	Reduzca la cantidad de alimentos guardados en el aparato
Hay fugas de agua en el aparato	El aparato no está bien nivelado	Ajuste las patas enroscadas para nivelar el aparato (si es aplicable)
	La salida de descarga está bloqueada	Limpie la salida de descarga
	El movimiento del agua hacia el desagüe está obstruido	Limpie la base del aparato (si es aplicable)
	El contenedor de agua está dañado	Llame a un técnico calificado
	La bandeja de goteo está rebosando	Vacíe la bandeja de goteo (si es aplicable)
El aparato es inusualmente ruidoso	No se ha retirado la banda de seguridad	Retire la banda de seguridad
	Tuerca / tornillo flojo	Compruebe y apriete todas los tornillos y las tuercas

## Especificaciones Técnicas(Otros detalles ver inserto)(R290)

Modelo	Voltaje	Corriente	Margen de Temperaturas	Capacidad (litros)	Dimensiones a×x×p (mm)	Peso (Kg)
GN2100BT	220-240V 50Hz	3.0A	-10°C ~ -20°C	314 Vn:206	1360×700×860	97
GN3100BT	220-240V 50Hz	3.0A	-10°C ~ -20°C	465 Vn:309	1795×700×860	117
GN4100BT	220-240V 50Hz	4.0A	-10°C ~ -20°C	616 Vn:412	2230×700×860	146
GN2200BT	220-240V 50Hz	3.0A	-10°C ~ -20°C	314 Vn:206	1360×700×960	103
GN3200BT	220-240V 50Hz	3.0A	-10°C ~ -20°C	465 Vn:309	1795×700×960	130
GN4200BT	220-240V 50Hz	4.0A	-10°C ~ -20°C	616 Vn:412	2230×700×960	160
SNACK2100BT	220-240V 50Hz	3.0A	-10°C ~ -20°C	260 Vn:172	1360×600×860	86
SNACK3100BT	220-240V 50Hz	3.0A	-10°C ~ -20°C	386	1795×600×860	107
SNACK4100BT	220-240V 50Hz	4.0A	-10°C ~ -20°C	511 Vn:344	2230×600×860	133
SNAC2200BT	220-240V 50Hz	3.0A	-10°C ~ -20°C	260 Vn:172	1360×600×960	99
SNACK3200BT	220-240V 50Hz	3.0A	-10°C ~ -20°C	386 Vn:258	1795×600×960	120
SNACK4200BT	220-240V 50Hz	4.0A	-10°C ~ -20°C	511 Vn:344	2230×600×960	147
GN2100TN	220-240V 50Hz	1.2A	-2°C ~ +8°C	314 Vn:206	1360×700×860	93
GN2100TNG	220-240V 50Hz	1.2A	+2°C ~ +8°C	314	1360×700×860	98
GN2200TN	220-240V 50Hz	1.2A	-2°C ~ +8°C	314 Vn:206	1360×700×960	95
GN2200TNG	220-240V 50Hz	1.2A	+2°C ~ +8°C	314	1360×700×960	100
GN3100TN	220-240V 50Hz	1.2A	-2°C ~ +8°C	465 Vn:309	1795×700×860	114
GN3100TNG	220-240V 50Hz	1.2A	+2°C ~ +8°C	465	1795×700×860	126
GN3200TN	220-240V 50Hz	1.2A	-2°C ~ +8°C	465	1795×700×960	125
GN3200TNG	220-240V 50Hz	1.2A	+2°C ~ +8°C	465	1795×700×960	137
GN4100TN	220-240V 50Hz	1.3A	-2°C ~ +8°C	616 Vn:412	2230×700×860	138

Modelo	Voltaje	Corriente	Margen de Temperaturas	Capacidad (litros)	Dimensiones a×x×p (mm)	Peso (Kg)
GN4100TNG	220-240V 50Hz	1.3A	+2°C ~ +8°C	616	2230×700×860	150
GN4200TN	220-240V 50Hz	1.3A	-2°C ~ +8°C	616 Vn:412	2230×700×960	152
GN4200TNG	220-240V 50Hz	1.3A	+2°C ~ +8°C	616	2230×700×960	164
PA2100TN	220-240V 50Hz	1.2A	+2°C ~ +8°C	428 Vn:304	1510×800×860	105
PA2200TN	220-240V 50Hz	1.2A	+2°C ~ +8°C	428	1510×800×960	116
PA3100TN	220-240V 50Hz	1.3A	+2°C ~ +8°C	635 Vn:456	2020×800×860	132
PA3200TN	220-240V 50Hz	1.3A	+2°C ~ +8°C	635 Vn:456	2020×800×960	146
SNACK2100TN	220-240V 50Hz	1.2A	-2°C ~ +8°C	260	1360×600×860	81
SNACK2100TNG	220-240V 50Hz	1.2A	+2°C ~ +8°C	260	1360×600×860	95
SNACK2200TN	220-240V 50Hz	1.2A	-2°C ~ +8°C	260 Vn:172	1360×600×960	94
SNACK2200TNG	220-240V 50Hz	1.2A	+2°C ~ +8°C	260	1360×600×960	108
SNACK3100TN	220-240V 50Hz	1.2A	-2°C ~ +8°C	386 Vn:258	1795×600×860	102
SNACK3100TNG	220-240V 50Hz	1.2A	+2°C ~ +8°C	386	1795×600×860	116
SNACK3200TN	220-240V 50Hz	1.2A	-2°C ~ +8°C	386 Vn:258	1795×600×960	115
SNACK3200TNG	220-240V 50Hz	1.2A	+2°C ~ +8°C	386	1795×600×960	129
SNACK4100TN	220-240V 50Hz	1.3A	-2°C ~ +8°C	511	2230×600×860	126
SNACK4100TNG	220-240V 50Hz	1.3A	+2°C ~ +8°C	511	2230×600×860	130
SNACK4200TN	220-240V 50Hz	1.3A	-2°C ~ +8°C	511 Vn:344	2230×600×960	140
SNACK4200TNG	220-240V 50Hz	1.3A	+2°C ~ +8°C	511	2230×600×960	155
U-GN2100TN	220-240V 50Hz	1.2A	-2°C ~ +8°C	214 Vn:130	1360×700×650	80
U-GN2140TN	220-240V 50Hz	1.2A	-2°C ~ +8°C	214 Vn:130	1360×700×650	93
U-GN2100TN	220-240V 50Hz	1.2A	-2°C ~ +8°C	214 Vn:130	1360×700×650	80
U-GN2140TN	220-240V 50Hz	1.2A	-2°C ~ +8°C	214 Vn:130	1360×700×650	93

Modelo	Voltaje	Corriente	Margen de Temperaturas	Capacidad (litros)	Dimensiones a×a×p (mm)	Peso (Kg)
U-GN3100TN	220-240V 50Hz	1.2A	-2°C ~ +8°C	317 Vn:195	1795×700×650	104
U-GN3160TN	220-240V 50Hz	1.2A	-2°C ~ +8°C	317 Vn:195	1795×700×650	123
U-GN4100TN	220-240V 50Hz	1.3A	-2°C ~ +8°C	420	2230×700×650	125
U-GN4180TN	220-240V 50Hz	1.3A	-2°C ~ +8°C	420 Vn:260	2230×700×650	150
SH2000/700	220-240V 50Hz	1.3A	+2°C ~ +8°C	396	1360×700×1085	100
SH2000/800	220-240V 50Hz	1.3A	+2°C ~ +8°C	459	1510×800×1085	115
SH3000/700	220-240V 50Hz	1.3A	+2°C ~ +8°C	470	1795×700×1085	121
SH3000/800	220-240V 50Hz	1.3A	+2°C ~ +8°C	576	2020×800×1085	145
PZ1610TN	220-240V 50Hz	1.2A	+2°C ~ +8°C	221	1515×800×1000	256
PZ2600TN	220-240V 50Hz	1.2A	+2°C ~ +8°C	428 Vn:304	1510×800×1000	234
PH2610TN	220-240V 50Hz	1.2A	+2°C ~ +8°C	428 Vn:304	2025×800×1000	334
PZ3600TN	220-240V 50Hz	1.3A	+2°C ~ +8°C	635	2025×800×1000	294

## Cableado Eléctrico

El enchufe tiene que conectarse a una toma eléctrica adecuada. Este aparato está conectado de la forma siguiente:

- Cable cargado (de color marrón) a la terminal marcada como **L**
- Cable neutro (de color azul) a la terminal marcada como **N**
- Cable de tierra (de color verde / amarillo) a la terminal marcada como **E**

El aparato debe estar conectado a tierra, utilizando un circuito de conexión a tierra especializado. Si tiene alguna duda, consulte a un electricista calificado.

Los puntos de aislamiento eléctrico deben mantenerse libres de cualquier obstrucción. En caso de precisarse una desconexión de emergencia, deben estar disponibles de forma inmediata.

## Desecho

Las normativas de la UE requieren que los productos de refrigeración sean desechados por compañías especializadas que extraigan o reciclen todos los gases, componentes metálicos y de plástico.

Consulte a su autoridad local de recolección de residuos a la hora de desechar su aparato. Las autoridades locales no están obligadas a eliminar los equipos de refrigeración comerciales pero pueden ofrecer consejo sobre cómo desechar los equipos localmente.

## Cumplimiento

Las piezas han pasado estrictas pruebas de productos para cumplir las especificaciones y normas reguladoras establecidas por las autoridades internacionales, independientes y federales.

Los productos han sido autorizados para llevar el símbolo siguiente.

**Refrigerante R600a y R290 utilizan este refrigerador**



### ADVERTENCIA:

Mantenga las aberturas de ventilación, en el gabinete del aparato o en la estructura incorporada, es necesario que eliminar obstrucciones.

Aparte de los dispositivos recomendados por el fabricante, no puede utilizar dispositivos mecánicos u otros medios para acelerar el proceso de descongelación, distintos de los recomendados por el fabricante.

No dañe el circuito de refrigerante.

No utilice electrodomésticos en los compartimentos de almacenamiento de alimentos del aparato a menos que sea el tipo recomendado por el fabricante.



EN CASO DE QUE EL CABLE DE ALIMENTACIÓN ESTÉ DAÑADO, EL FABRICANTE O EL SERVICIO POSVENTA, O UN TÉCNICO CUALIFICADO SUSTITUIRLO PARA EVITAR LOS POSIBLES RIESGO.

LA REPARACIÓN Y SUSTITUCIÓN DE LA LÁMPARA DEBERÁN SER EFECTUADA POR TÉCNICOS CUALIFICADOS, CON LA ALIMENTACIÓN DESCONECTADA. REEMPLAZAR CON LÁMPARAS IDÉNTICAS.

SÓLO TÉCNICOS CUALIFICADOS REALIZARÁN LAS EXTRAORDINARIAS INTERVENCIONES DE MANTENIMIENTO.



### Eliminación del embalaje

AJI materiales de embalaje deben eliminarse por una manera respetuosa con el medio ambiente. El cartón se puede utilizar como papel de desecho. La lámina protectora y los cojines de espuma son CFC -libre.

No permita que los niños jueguen con el embalaje y destruya las bolsas de plástico por la forma segura.

Usted puede romper o cortar el cartón en trozos más pequeños y dar a un servicio de eliminación de papel de desecho.



### Protección del medio ambiente

¡Los electrodomésticos desechados son reciclables y no deben ser desechados en la basura doméstica! Por favor, ayúdenos activamente a conservar los recursos y proteger el medio ambiente, devolviendo este aparato a los centros de recolección (si están disponibles).



## Conseils de sécurité

- Conseils de sécurité.
- Placez l'appareil sur une surface plane, stable.
- L'installation et les éventuelles réparations doivent être confiées à un dépanneur / technicien qualifié. Ne retirez aucun composant ou cache de ce produit.
- Consultez les normes locales et nationales pour vous conformer aux:
  - lois sur l'hygiène et la sécurité au travail
  - codes de bonnes pratiques BS EN
  - précautions contre le risque d'incendie
  - réglementation sur les branchements électriques IEE
  - règlements sur la construction
- NE PAS nettoyer cet appareil avec un nettoyeur à jet / à pression.
- NE PAS se servir de cet appareil pour stocker des médicaments.
- NE PAS utiliser d'appareils électriques à l'intérieur de l'appareil (ex, chauffages, sorbetières, etc.).
- NE PAS se tenir debout sur le châssis, les tiroirs ou les portes ou s'y accouder
- NE PAS éclabousser les composants en plastique ou les joints de porte d'huile ou de matières grasses. En cas d'éclaboussure, nettoyez immédiatement la surface touchée.
- Cet appareil est réservé exclusivement à une utilisation à l'intérieur.
- Les bouteilles qui contiennent un haut pourcentage d'alcool doivent être bouchonnées et rangées à la verticale dans le réfrigérateur.
- Veillez à toujours transporter, stocker et manipuler l'appareil à la verticale et à le déplacer en tenant la base du châssis.
- N'oubliez jamais d'éteindre et de débrancher l'appareil avant de procéder à son nettoyage.
- Gardez les emballages hors de portée des enfants. Débarrassez vous des emballages conformément aux règlements des autorités locales.
- Un cordon d'alimentation endommagé doit être remplacé par un agent ou un technicien qualifié recommandé pour éviter tout danger.

## Introduction

Nous vous invitons à consacrer quelques instants à la lecture attentive de ce mode d'emploi. L'entretien et l'utilisation appropriés de cette machine vous permettront de tirer le meilleur de votre produit.

## Contenu de l'emballage

Les éléments suivants vous sont fournis de série:

- Réfrigérateur ou congélateur
- Supports de clayettes (deux par porte)
- Clayettes (1 par porte)
- Mode d'emploi

Nous attachons une grande importance à la qualité et au service et veillons à fournir des produits en parfait état opérationnel, parfaitement intacts au moment de l'emballage.

Nous vous prions de contacter votre revendeur immédiatement si vous constatez un dommage

quelconque survenu pendant le transport du produit.

## Installation

**Φ Remarque: dans les cas où l'appareil a été stocké ou déplacé autrement qu'à la verticale, placez-le en position debout pendant environ 12 heures avant de l'utiliser. En cas de doute, laissez l'appareil se reposer.**

1. Sortez l'appareil de l'emballage. Veillez à bien retirer toute la pellicule et les revêtements de protection de toutes les surfaces.
2. Veillez à prévoir une distance de 20 cm entre l'appareil et les murs ou autres objets, pour laisser l'air circuler. Augmentez cette distance si l'obstacle est une source de chaleur.

**Φ Remarque: Avant de mettre l'appareil en service pour la première fois ; nettoyez les clayettes et l'intérieur de l'appareil à l'eau savonneuse.**

3. Bloquez les freins des roulettes de l'appareil, pour l'empêcher de bouger **OU** Mettez l'appareil de niveau en réglant les pieds à vis.

## Installation des clayettes

1. Placez une paire de supports de clayettes de part et d'autre de l'armoire, à la hauteur voulue.
2. Introduisez la clayette.
3. Répétez cette opération pour les autres clayettes.

**Φ Remarque: cette consigne est vitale pour assurer des évacuations des résidus de condensation.**

## Fonctionnement

### Stockage des aliments

Suivez ces consignes pour profiter au mieux de votre appareil:

- Ne stockez des aliments dans l'appareil que lorsqu'il a atteint la bonne température de fonctionnement.
- Ne placez aucun aliment ou liquide chaud non couverts à l'intérieur de l'appareil.
- Autant que faire se peut, enveloppez ou couvrez les aliments.
- Veillez à ne pas obstruer les ventilateurs à l'intérieur de l'appareil.
- Évitez de laisser trop longtemps les portes ouvertes.

### Mise en service

1. Fermez la / les porte(s) de l'appareil.
2. Vérifiez que l'interrupteur marche / arrêt est réglé sur [O] et allumez la prise.
3. Mettez l'appareil sous tension, position [I]. La température à l'intérieur de l'appareil s'affiche.

### Décongélation manuelle

L'appareil enclenche un cycle de décongélation toutes les six heures.

⚠ **Remarque: Le cycle débute à partir de la mise en service initiale de l'appareil.**

Pour décongeler l'appareil, manuellement:

1. Appuyez sur et maintenez enfoncé le bouton DEFROST (Décongélation)  pendant cinq secondes.
2. Le cycle de décongélation démarre immédiatement et la diode de décongélation s'allume. La décongélation ne dure pas plus de 30 minutes.

⚠ **Remarque: Le démarrage d'une décongélation manuelle entraîne également ma réinitialisation du temporisateur de décongélation automatique. La décongélation automatique suivante démarre six heures après écoulement du temps de décongélation manuelle.**

L'eau usée est recueillie dans le plateau de récupération des eaux usées.

## Nettoyage, entretien et maintenance

- N'oubliez jamais d'éteindre et de débrancher l'appareil avant de procéder à son nettoyage.
- Nettoyez l'intérieur de l'appareil aussi souvent que possible.
- N'utilisez aucun produit de nettoyage abrasif. Ces produits peuvent laisser des résidus nocifs.
- Le joint de porte ne se nettoie qu'à l'eau.
- Veillez à le sécher en l'essuyant après nettoyage.
- Ne laissez pas l'eau de nettoyage s'écouler à travers l'orifice de vidange du bac d'évaporation.
- Soyez prudent quand vous nettoyez l'arrière de l'appareil. Les bords effilés peuvent couper.
- Toute réparation doit être confiée à un agent ou à un technicien qualifié.

## Nettoyage du condensateur

1. Nettoyer régulièrement le condensateur peut prolonger la durée de vie de l'appareil.
2. Vous recommandons de confier le nettoyage du condensateur à un agent ou à un technicien qualifié.

## Dépannage

En cas de dysfonctionnement de votre appareil, veuillez vérifier les données du tableau ci-dessous:

Dysfonctionnement	Cause probable	Intervention
L'appareil ne fonctionne pas	L'appareil n'est pas allumé	Vérifier que l'appareil est bien branché et allumé
	La prise et le cordon sont endommagés	Appeler un agent ou un technicien qualifié
	Alimentation	Vérifier l'alimentation
	Problème de branchement interne	Appeler un agent ou un technicien qualifié
	Excès de glace sur le condensateur	Décongeler l'appareil
L'appareil s'allume, mais la température est trop haute / basse	Le condensateur est saturé de poussières	Appeler un agent ou un technicien qualifié
	Les portes sont mal fermées	Vérifier que les portes sont fermées et l'état des joints
	L'appareil est situé près d'une source de chaleur ou l'air ne circule pas librement vers le condensateur	Déplacer le réfrigérateur pour le placer à un endroit, mieux adapté
	Température ambiante trop haute	Augmenter la ventilation ou placer l'appareil à un endroit mieux adapté
	Des aliments inadéquats sont stockés dans l'appareil	Retirer les aliments trop chauds ou les éventuelles obstructions au ventilateur
	L'appareil est surchargé	Réduire la quantité d'aliments stockés dans l'appareil
	L'appareil n'est pas de niveau	Régler les pieds à vis pour le mettre de niveau (le cas échéant)
Fuite d'eau	Evacuation bouchée	Déboucher l'évacuation
	Circuit de vidange bouché	Nettoyer le plancher de l'appareil (le cas échéant)
	Bac à eau endommagé	Appeler un agent ou un technicien qualifié
	La cuvette de dégivrage déborde	Vider la cuvette de dégivrage (le cas échéant)
	La sangle de sécurité n'a pas été retirée	Retirer la sangle de sécurité

Dysfonctionnement	Cause probable	Intervention
L'appareil fait beaucoup de bruit	Ecrou / vis desserrés	Vérifier et resserrer les écrous et vis
	La surface sur laquelle l'appareil a été posé n'est pas de niveau ou l'appareil n'est pas stable	Vérifier la position d'installation et la changer si nécessaire

## Spécifications techniques (Autres détails voir encart)(R290)

Modèle	Tension	Courant	Plage de température	Capacité (litres)	Dimensions h×l×p (mm)	Poids (Kg)
GN2100BT	220-240V 50Hz	3.0A	-10°C ~ -20°C	314 Vn:206	1360×700×860	97
GN3100BT	220-240V 50Hz	3.0A	-10°C ~ -20°C	465 Vn:309	1795×700×860	117
GN4100BT	220-240V 50Hz	4.0A	-10°C ~ -20°C	616 Vn:412	2230×700×860	146
GN2200BT	220-240V 50Hz	3.0A	-10°C ~ -20°C	314 Vn:206	1360×700×960	103
GN3200BT	220-240V 50Hz	3.0A	-10°C ~ -20°C	465 Vn:309	1795×700×960	130
GN4200BT	220-240V 50Hz	4.0A	-10°C ~ -20°C	616 Vn:412	2230×700×960	160
SNACK2100BT	220-240V 50Hz	3.0A	-10°C ~ -20°C	260 Vn:172	1360×600×860	86
SNACK3100BT	220-240V 50Hz	3.0A	-10°C ~ -20°C	386	1795×600×860	107
SNACK4100BT	220-240V 50Hz	4.0A	-10°C ~ -20°C	511 Vn:344	2230×600×860	133
SNACK2200BT	220-240V 50Hz	3.0A	-10°C ~ -20°C	260 Vn:172	1360×600×960	99
SNACK3200BT	220-240V 50Hz	3.0A	-10°C ~ -20°C	386 Vn:258	1795×600×960	120
SNACK4200BT	220-240V 50Hz	4.0A	-10°C ~ -20°C	511 Vn:344	2230×600×960	147
GN2100TN	220-240V 50Hz	1.2A	-2°C ~ +8°C	314 Vn:206	1360×700×860	93
GN2100TNG	220-240V 50Hz	1.2A	+2°C ~ +8°C	314	1360×700×860	98
GN2200TN	220-240V 50Hz	1.2A	-2°C ~ +8°C	314 Vn:206	1360×700×960	95
GN2200TNG	220-240V 50Hz	1.2A	+2°C ~ +8°C	314	1360×700×960	100
GN3100TN	220-240V 50Hz	1.2A	-2°C ~ +8°C	465 Vn:309	1795×700×860	114

Modèle	Tension	Courant	Plage de température	Capacité (litres)	Dimensions h×l×p (mm)	Poids (Kg)
GN3100TNG	220-240V 50Hz	1.2A	+2°C ~ +8°C	465	1795×700×860	126
GN3200TN	220-240V 50Hz	1.2A	-2°C ~ +8°C	465	1795×700×960	125
GN3200TNG	220-240V 50Hz	1.2A	+2°C ~ +8°C	465	1795×700×960	137
GN4100TN	220-240V 50Hz	1.3A	-2°C ~ +8°C	616	2230×700×860	138
GN4100TNG	220-240V 50Hz	1.3A	+2°C ~ +8°C	616	2230×700×860	150
GN4200TN	220-240V 50Hz	1.3A	-2°C ~ +8°C	616 Vn:412	2230×700×960	152
GN4200TNG	220-240V 50Hz	1.3A	+2°C ~ +8°C	616	2230×700×960	164
PA2100TN	220-240V 50Hz	1.2A	+2°C ~ +8°C	428 Vn:304	1510×800×860	105
PA2200TN	220-240V 50Hz	1.2A	+2°C ~ +8°C	428 Vn:304	1510×800×960	116
PA3100TN	220-240V 50Hz	1.3A	+2°C ~ +8°C	635 Vn:456	2020×800×860	132
PA3200TN	220-240V 50Hz	1.3A	+2°C ~ +8°C	635	2020×800×960	146
SNACK2100TN	220-240V 50Hz	1.2A	-2°C ~ +8°C	260 Vn:172	1360×600×860	81
SNACK2100TNG	220-240V 50Hz	1.2A	+2°C ~ +8°C	260	1360×600×860	95
SNACK2200TN	220-240V 50Hz	1.2A	-2°C ~ +8°C	260	1360×600×960	94
SNACK2200TNG	220-240V 50Hz	1.2A	+2°C ~ +8°C	260	1360×600×960	108
SNACK3100TN	220-240V 50Hz	1.2A	-2°C ~ +8°C	386 Vn:258	1795×600×860	102
SNACK3100TNG	220-240V 50Hz	1.2A	+2°C ~ +8°C	386	1795×600×860	116
SNACK3200TN	220-240V 50Hz	1.2A	-2°C ~ +8°C	386 Vn:258	1795×600×960	115
SNACK3200TNG	220-240V 50Hz	1.2A	+2°C ~ +8°C	386	1795×600×960	129
SNACK4100TN	220-240V 50Hz	1.3A	-2°C ~ +8°C	511 Vn:344	2230×600×860	126
SNACK4100TNG	220-240V 50Hz	1.3A	+2°C ~ +8°C	511	2230×600×860	130
SNACK4200TN	220-240V 50Hz	1.3A	-2°C ~ +8°C	511	2230×600×960	140
SNACK4200TNG	220-240V 50Hz	1.3A	+2°C ~ +8°C	511	2230×600×960	155

Modèle	Tension	Courant	Plage de température	Capacité (litres)	Dimensions h×l×p (mm)	Poids (Kg)
U-GN2100TN	220-240V 50Hz	1.2A	-2°C ~ +8°C	214 Vn:130	1360×700×650	80
U-GN2140TN	220-240V 50Hz	1.2A	-2°C ~ +8°C	214	1360×700×650	93
U-GN2100TN	220-240V 50Hz	1.2A	-2°C ~ +8°C	214 Vn:130	1360×700×650	80
U-GN2140TN	220-240V 50Hz	1.2A	-2°C ~ +8°C	214 Vn:130	1360×700×650	93
U-GN3100TN	220-240V 50Hz	1.2A	-2°C ~ +8°C	317 Vn:195	1795×700×650	104
U-GN3160TN	220-240V 50Hz	1.2A	-2°C ~ +8°C	317 Vn:195	1795×700×650	123
U-GN4100TN	220-240V 50Hz	1.3A	-2°C ~ +8°C	420 Vn:260	2230×700×650	125
U-GN4180TN	220-240V 50Hz	1.3A	-2°C ~ +8°C	420 Vn:260	2230×700×650	150
SH2000/700	220-240V 50Hz	1.3A	+2°C ~ +8°C	396	1360×700×1085	100
SH2000/800	220-240V 50Hz	1.3A	+2°C ~ +8°C	459	1510×800×1085	115
SH3000/700	220-240V 50Hz	1.3A	+2°C ~ +8°C	470	1795×700×1085	121
SH3000/800	220-240V 50Hz	1.3A	+2°C ~ +8°C	576	2020×800×1085	145
PZ1610TN	220-240V 50Hz	1.2A	+2°C ~ +8°C	221	1515×800×1000	256
PZ2600TN	220-240V 50Hz	1.2A	+2°C ~ +8°C	428 Vn:304	1510×800×1000	234
PH2610TN	220-240V 50Hz	1.2A	+2°C ~ +8°C	428 Vn:304	2025×800×1000	334
PZ3600TN	220-240V 50Hz	1.3A	+2°C ~ +8°C	635 Vn:456	2025×800×1000	294

## Raccordement électrique

La prise doit être reliée à la prise secteur qui convient. Cet appareil est câblé comme suit:

- Fil conducteur (brun) à la borne marquée L
- Fil neutre (bleu) à la borne marquée N
- Fil de terre (vert / jaune) à la borne marquée E

Cet appareil doit être raccordé à la terre, par le biais d'un circuit de mise à la terre dédié.

En cas de doute, consultez un électricien qualifié.

Les points d'isolation électrique doivent être libres de toute obstruction. En cas de débranchement requis en urgence, ils doivent être facilement accessibles.

## Mise au rebut

Les règlements de l'UE exigent que les produits munis de réfrigérants soient mis au rebut par des entreprises spécialisées, équipées pour extraire et recycler les composants à gaz, métalliques et en plastique.

Adressez-vous à votre autorité chargée de la collecte des déchets pour ce qui concerne la mise au rebut de votre appareil.

même si rien n'oblige les autorités locales à se charger de la mise au rebut du matériel de réfrigération commerciale, elles pourraient être en mesure de vous conseiller sui les moyens disponibles localement pour s'en débarrasser.

## Conformité

Les pièces ont été soumises à des tests rigoureux pour pouvoir être déclarées aux normes et spécifications réglementaires définies par les autorités internationales, indépendantes et fédérales.  
Les produits ont été déclarés aptes à porter le symbole suivant.

### Les réfrigérant R600a et R290 utilisé par ce réfrigérateur



#### AVERTISSEMENT:

Gardez des ouvertures de ventilation, dans l'enceinte de l'appareil ou dans la structure intégrée, sans obstacles.

Pas utilisez les appareils mécaniques ou d'autres moyens pour accélérer le processus de dégivrage, sauf ceux recommandés par le fabricant.

Pas endommagez le circuit frigorifique.

Pas utilisez les appareils électriques à l'intérieur des compartiments de stockage d'aliments de l'appareil, à moins qu'ils soient du type recommandé par le fabricant.



DANS LE CAS OU LE CABLE D'ALIMENTATION EST ENDOMMAGE, LE FABRICANT OU LE SERVICE APRES-VENTE, OU UN TECHNICIEN QUALIFIE DEVRAIT LE REMPLACER, AFIN EVITER TOUT RISQUE POSSIBLE.

LA RÉPARATION ET LE REMPLACEMENT DE LA LAMPE DOIVENT ÊTRE EFFECTUÉS PAR LES TECHNICIENS QUALIFIÉS, AVEC L'ALIMENTATION DÉBRANCHÉE, REMPLACER PAR DES LAMPES IDENTIQUES.

SEULEMENT LES TECHNICIENS QUALIFIES PEUVENT EFFECTUER LES INTERVENTIONS EXTRAORDINAIRES DE MAINTENANCE.



#### Disposition d'emballage

Tous les matériaux d'emballage doivent être disposés d'une manière respectueuse de l'environnement. Le carton peut être utilisé comme papier de rebut. Le film de protection et les coussins de mousse n'ont pas de CFC.

Pas laissez les enfants jouer avec l'emballage et détruire les sacs en plastique en toute sécurité.

Vous pouvez casser ou couper le carton en petits morceaux et donner à un service de disposition des déchets de papier.



#### Protection de l'environnement

Les appareils électriques mis au rebut sont recyclables et ne doivent pas être jetés dans les ordures ménagères! S'il vous plaît nous soutenir activement à la conservation des ressources et à la protection de l'environnement en retournant cet appareil aux centres de collecte (le cas échéant).



## Veiligheidstips

- Plaatsen op een vlakke en stabiele ondergrond.
- De installatie en eventuele reparaties zijn door een servicetechnicus / vaktechnicus uit te voeren. Verwijder geen componenten of servicepanelen van dit product.
- Raadpleeg en volg de plaatselijke en nationale regelgeving op m.b.t. tot het volgende:
  - Wetgeving van gezondheid en veiligheid op de werkplaats
  - Werkregels
  - Brandpreventie
  - IEE bekabelingsnormen
  - Bouwverordeningen
- Dit product NIET reinigen met spuit-/drukreinigers.
- Dit product NIET gebruiken voor de berging van medische producten.
- In dit product GEEN elektrische apparaten gebruiken (zoals bijv. verwarmers, ijsmakers, etc.).
- NIET op de kastbasis, lades en deuren staan of als ondersteuning gebruiken.
- Laat NIET toe dat olie of vet in contact komt met plastic componenten of deurafdichtingen. Onmiddellijk reinigen indien dit wel gebeurt.
- Uitsluitend geschikt voor gebruik binnenshuis.
- Flessen met een hoog alcoholpercentage moet goed worden gesloten en verticaal in de koelkast worden bewaard.
- Dit product altijd in een verticale positie vervoeren, opbergen en gebruiken. Het product aan de kastbasis vervoeren.
- Alvorens dit product te reinigen dient men altijd de stroomvoorziening uit te schakelen.
- Laat verpakkingsmateriaal niet binnen handbereik van kinderen. Verpakkingsmateriaal in overeenstemming met de regelgeving van de plaatselijke overheden als afval laten verwerken.
- Indien de stroomkabel beschadigd raakt, dient men deze door een technicus of een aanbevolen vaktechnicus te laten vervangen om gevaarlijke situaties te verhinderen.

## Inleiding

Neem de tijd en lees deze handleiding aandachtig door. Een correct gebruik en onderhoud van deze machine waarborgt de beste prestatie van uw product.

## Verpakkingsinhoud

De verpakking bevat het volgende:

- Koeling of vriezer
- Ladegeleider ( 2 per deur)
- Lades (1 per deur)
- Handleiding

Wij zijn trots op onze productkwaliteit en dienstverlening en waarborgen dat de inhoud van deze verpakking op het moment van verpakken volledig functioneel en vrij van schade is.

Mocht uw product door transport zijn beschadigd, neem dan onmiddellijk contact op met uw dealer.

## Installatie

**Φ Opmerking: Indien het apparaat niet in een rechtopstaande positie is opgeslagen of vervoerd, dient men het product 12 uur vóór gebruik in de rechtopstaande positie te plaatsen. Bij twijfel dient men het product in een rechtopstaande positie te plaatsen.**

1. Haal het product uit de verpakking. Zorg ervoor dat u de beschermingsfolie en –lagen van alle oppervlakken heeft verwijderd.
2. Voor een adequate ventilatie dient men een afstand van 20cm aan te houden tussen dit product of muren en andere objecten. Vergroef deze afstand indien het object een warmtebron is.

**Φ Opmerking: Voor het eerste gebruik van dit product dient u de lades en de binnenzijde met zeepwater te reinigen.**

3. Zer de remmen van de wieltjes om het product op zijn plaats vast te zetten OF nivelleer het product door de verstelbare poten aan te passen.

## Het plaatsen van de lades

1. Plaats één set van de ladegeleiders aan beide zijden van de kast en op zijn plaats..
2. Schuif de lade op zijn plaats.
3. Herhaal deze handeling voor de overige lades.

**Φ Opmerking: dit is uiterst belangrijk zodat een correcte afvoer van condenswater wordt gewaarborgd.**

## Bediening

### Opslag van levensmiddelen

Volg de volgende aanwijzingen voor de beste resultaten met uw product:

- Bewaar uitsluitend levensmiddelen in het product wanneer het product de juiste gebruikstemperatuur heeft bereikt.
- Plaats geen open warme levensmiddelen of vloeistof in het product.
- Voedsel bedekken en inwickelen wanneer mogelijk.
- Niet de interne ventilatoren in het product blokkeren.
- Laat de deuren niet al te lang openstaan.

### Inschakelen

1. Sluit de deur(en) van het product.
2. Controleer of stroomschakelaar in de positie [O] staat en de steker in het stopcontact zit.
3. Zet de Power (stroom) [I] aan. De actuele interne temperatuur van het product wordt weergegeven.

### Handmatig ontdooien

Het product zal om de zes uur een automatische ontdooicyclus draaien.

**Φ Opmerking: de cyclus gaat in bij de eerste opstart van het product.**

Voor de handmatige ontdooiing van het product:

1. De DEFROST (ontdooier)  knop indrukken en gedurende 5 seconden ingedrukt houden.
2. De ontdooicyclus zal onmiddellijk starten en het Defrost (ontdooier) LED licht op. Het ontdooiproces zal maximaal 30 minuten duren.

**Φ Opmerking: Het starten van een handmatig ontdooiproces zorgt tevens voor een automatische reset van de timer van de ontdooier. Het volgende automatische ontdooiproces start zes uur ná beëindiging van de handmatige ontdooiing.**

3. Afvoerwater wordt opgevangen in de afvoerwaterlade.

## Reiniging, zorg & onderhoud

- Alvorens het apparaat te reinigen dient men de.
- Stroomvoorziening uit te schakelen.
- Reinig zo vaak mogelijk de binnenkant van het product.
- Gebruik géén schurende reinigingsmiddelen. Dergelijke middelen kunnen schadelijke resten achterlaten.
- Reinig de deurafdichting uitsluitend met water.
- Na reiniging gebruikte water mag niet door het afvoergat naar de verdampingspan stromen.
- Ga voorzichtig te werk bij het reinigen van de achterzijde van het product. Scherpe randen kunnen snijwonden veroorzaken.
- Eventuele reparaties moeten door een technicus of een vaktechnicus worden uitgevoerd.

## Reiniging van de condensor

De periodieke reiniging van de condensor kan de technische levensduur van het product verlengen.

Het is de aanbeveling van om de reiniging van de condensor door een technicus of een vaktechnicus te laten uitvoeren.

## Oplossen van problemen

Indien er een storing van uw product optreedt, dient u de onderstaande tabel.

Probleem	Mogelijke oorzaak	Handeling
Het apparaat werkt niet	Het apparaat staat uit	Controleer of de stroomkabel van het apparaat is aangesloten en of het apparaat is ingeschakeld
	Steker en kabel zijn beschadigd	Laat een technicus of een vaktechnicus komen
	De zekering in de steker is gesprongen	Vervang de zekering in de steker
	Stroomvoorziening	Controleer de stroomvoorziening
	Storing interne bedrading	Laat een technicus of een vaktechnicus komen
Het product staat aan maar de temperatuur is te hoog/laag	Teveel ijs in de condensor	Ontdooi het product
	Condensor wordt geblokkeerd door stof	Laat een technicus of een vaktechnicus komen
	Deuren niet goed gesloten	Controleer of de deuren goed dicht en of afdichtingen niet beschadigd zijn
	Het product bevindt zich in de nabijheid van een warmtebron of de luchtstroom naar de condensor wordt onderbroken	Verplaats de koelkast naar een geschiktere locatie
	Omgevingstemperatuur is te hoog	Verbeter de ventilatie of verplaats het product naar een koelere locatie
	Ongeschikte levensmiddelen worden in het product bewaard	Verwijder alle overbodige warme levensmiddelen of deblokkeer de ventilator
Het product lekt water	Het product staat niet recht	Pas de verstelbare poten aan om het product te nivelleren (indien nodig)
	De afvoeropening wordt geblokkeerd	Maak de afvoeropening vrij van obstakels
	De waterstroom naar de afvoer wordt geblokkeerd	Maak de vloer vrij van obstakels (indien nodig)
	De waterbak is beschadigd	Laat een technicus of een vaktechnicus komen

Probleem	Mogelijke oorzaak	Handeling
	De druppellade stroomt over	Leeg de druppellade (indien nodig)
Het product maakt ongebruikelijk veel lawaai	U heeft de veiligheidsband niet verwijderd	Verwijder de veiligheidsband
	Moer/schroef los	Alle moeren en schroeven controleren en aantrekken

### Technische specificaties (Andere details zie bijlage) (R290)

Model	Voltage	Stroom	Temperatuurbereik	Inhoud (liters)	Afmetingen h×b×d (mm)	Gewicht (Kg)
GN2100BT	220-240V 50Hz	3.0A	-10°C ~ -20°C	314 Vn:206	1360×700×860	97
GN3100BT	220-240V 50Hz	3.0A	-10°C ~ -20°C	465 Vn:309	1795×700×860	117
GN4100BT	220-240V 50Hz	4.0A	-10°C ~ -20°C	616 Vn:412	2230×700×860	146
GN2200BT	220-240V 50Hz	3.0A	-10°C ~ -20°C	314 Vn:206	1360×700×960	103
GN3200BT	220-240V 50Hz	3.0A	-10°C ~ -20°C	465 Vn:309	1795×700×960	130
GN4200BT	220-240V 50Hz	4.0A	-10°C ~ -20°C	616 Vn:412	2230×700×960	160
SNACK2100BT	220-240V 50Hz	3.0A	-10°C ~ -20°C	260 Vn:172	1360×600×860	86
SNACK3100BT	220-240V 50Hz	3.0A	-10°C ~ -20°C	386	1795×600×860	107
SNACK4100BT	220-240V 50Hz	4.0A	-10°C ~ -20°C	511 Vn:344	2230×600×860	133
SNAC2200BT	220-240V 50Hz	3.0A	-10°C ~ -20°C	260 Vn:172	1360×600×960	99
SNACK3200BT	220-240V 50Hz	3.0A	-10°C ~ -20°C	386 Vn:258	1795×600×960	120
SNACK4200BT	220-240V 50Hz	4.0A	-10°C ~ -20°C	511 Vn:344	2230×600×960	147
GN2100TN	220-240V 50Hz	1.2A	-2°C ~ +8°C	314 Vn:206	1360×700×860	93
GN2100TNG	220-240V 50Hz	1.2A	+2°C ~ +8°C	314	1360×700×860	98
GN2200TN	220-240V 50Hz	1.2A	-2°C ~ +8°C	314 Vn:206	1360×700×960	95
GN2200TNG	220-240V 50Hz	1.2A	+2°C ~ +8°C	314	1360×700×960	100
GN3100TN	220-240V 50Hz	1.2A	-2°C ~ +8°C	465 Vn:309	1795×700×860	114
GN3100TNG	220-240V 50Hz	1.2A	+2°C ~ +8°C	465	1795×700×860	126

Model	Voltage	Stroom	Temperatuurbe- reik	Inhoud (liters)	Afmetingen h×b×d (mm)	Gewicht (Kg)
GN3200TN	220-240V 50Hz	1.2A	-2°C ~ +8°C	465	1795×700×960	125
GN3200TNG	220-240V 50Hz	1.2A	+2°C ~ +8°C	465	1795×700×960	137
GN4100TN	220-240V 50Hz	1.3A	-2°C ~ +8°C	616	2230×700×860	138
GN4100TNG	220-240V 50Hz	1.3A	+2°C ~ +8°C	616	2230×700×860	150
GN4200TN	220-240V 50Hz	1.3A	-2°C ~ +8°C	616 Vn:412	2230×700×960	152
GN4200TNG	220-240V 50Hz	1.3A	+2°C ~ +8°C	616	2230×700×960	164
PA2100TN	220-240V 50Hz	1.2A	+2°C ~ +8°C	428 Vn:304	1510×800×860	105
PA2200TN	220-240V 50Hz	1.2A	+2°C ~ +8°C	428 Vn:304	1510×800×960	116
PA3100TN	220-240V 50Hz	1.3A	+2°C ~ +8°C	635 Vn:456	2020×800×860	132
PA3200TN	220-240V 50Hz	1.3A	+2°C ~ +8°C	635	2020×800×960	146
SNACK2100TN	220-240V 50Hz	1.2A	-2°C ~ +8°C	260 Vn:172	1360×600×860	81
SNACK2100TNG	220-240V 50Hz	1.2A	+2°C ~ +8°C	260	1360×600×860	95
SNACK2200TN	220-240V 50Hz	1.2A	-2°C ~ +8°C	260	1360×600×960	94
SNACK2200TNG	220-240V 50Hz	1.2A	+2°C ~ +8°C	260	1360×600×960	108
SNACK3100TN	220-240V 50Hz	1.2A	-2°C ~ +8°C	386 Vn:258	1795×600×860	102
SNACK3100TNG	220-240V 50Hz	1.2A	+2°C ~ +8°C	386	1795×600×860	116
SNACK3200TN	220-240V 50Hz	1.2A	-2°C ~ +8°C	386 Vn:258	1795×600×960	115
SNACK3200TNG	220-240V 50Hz	1.2A	+2°C ~ +8°C	386	1795×600×960	129
SNACK4100TN	220-240V 50Hz	1.3A	-2°C ~ +8°C	511 Vn:344	2230×600×860	126
SNACK4100TNG	220-240V 50Hz	1.3A	+2°C ~ +8°C	511	2230×600×860	130
SNACK4200TN	220-240V 50Hz	1.3A	-2°C ~ +8°C	511	2230×600×960	140
SNACK4200TNG	220-240V 50Hz	1.3A	+2°C ~ +8°C	511	2230×600×960	155
U-GN2100TN	220-240V 50Hz	1.2A	-2°C ~ +8°C	214 Vn:130	1360×700×650	80
U-GN2140TN	220-240V 50Hz	1.2A	-2°C ~ +8°C	214	1360×700×650	93

Model	Voltage	Stroom	Temperatuurbereik	Inhoud (liters)	Afmetingen h×b×d (mm)	Gewicht (Kg)
U-GN2100TN	220-240V 50Hz	1.2A	-2°C ~ +8°C	214 Vn:130	1360×700×650	80
U-GN2140TN	220-240V 50Hz	1.2A	-2°C ~ +8°C	214 Vn:130	1360×700×650	93
U-GN3100TN	220-240V 50Hz	1.2A	-2°C ~ +8°C	317 Vn:195	1795×700×650	104
U-GN3160TN	220-240V 50Hz	1.2A	-2°C ~ +8°C	317 Vn:195	1795×700×650	123
U-GN4100TN	220-240V 50Hz	1.3A	-2°C ~ +8°C	420 Vn:260	2230×700×650	125
U-GN4180TN	220-240V 50Hz	1.3A	-2°C ~ +8°C	420 Vn:260	2230×700×650	150
SH2000/700	220-240V 50Hz	1.3A	+2°C ~ +8°C	396	1360×700×1085	100
SH2000/800	220-240V 50Hz	1.3A	+2°C ~ +8°C	459	1510×800×1085	115
SH3000/700	220-240V 50Hz	1.3A	+2°C ~ +8°C	470	1795×700×1085	121
SH3000/800	220-240V 50Hz	1.3A	+2°C ~ +8°C	576	2020×800×1085	145
PZ1610TN	220-240V 50Hz	1.2A	+2°C ~ +8°C	221	1515×800×1000	256
PZ2600TN	220-240V 50Hz	1.2A	+2°C ~ +8°C	428 Vn:304	1510×800×1000	234
PH2610TN	220-240V 50Hz	1.2A	+2°C ~ +8°C	428 Vn:304	2025×800×1000	334
PZ3600TN	220-240V 50Hz	1.3A	+2°C ~ +8°C	635 Vn:456	2025×800×1000	294

## Elektrische bedrading

Men dient de steker op een geschikt stopcontact aan te sluiten. De bedrading van dit apparaat is als volgt:

- Stroomkabel (bruin) naar de aansluitklem gemarkeerd met **L**
- Neutraalkabel (blauw) naar de aansluitklem gemarkeerd met **N**
- Aardekabel (groen/geel) naar de aansluitklem gemarkeerd met **E**

Dit apparaat moet worden geaard met behulp van een adequaat aardingscircuit.

Bij twijfels raadpleeg een vakkundige elektricien.

De elektrische isolatiepunten mogen niet worden geblokkeerd. In geval van een nooduitschakeling moeten de isolatiepunten direct toegankelijk zijn.

## Afvalverwerking

De EU-richtlijnen vereisen dat koelproducten door gespecialiseerde bedrijven wordt verwerkt die gassen, metalen en plastic componenten verwijderen of recyclen.

Raadpleeg uw plaatselijke afvalverwerkingsbedrijf voor informatie over de afvalverwerking van uw apparaat. De plaatselijke overheden zijn niet verplicht om koeling sproducten van bedrijven als agval te verwerken maar kunnen uw informeren waar u het apparaat kunt afgeven.

## Product conformiteit

De onderdelen van producten hebben strenge product testen ondergaan om te voldoen aan wettelijke regels en specificaties die door internationale, onafhankelijke en landelijke overheden worden voorgeschreven. Producten zijn goedgekeurd en voorzien van het volgende symbool.

**Koelmiddelen R600a en R290 worden gebruikt in deze koelkast**



**WAARSCHUWING:**

Houd de ventilatieopeningen in de behuizing van het toestel open.

Geen mechanische apparaten of andere middelen, anders dan die aanbevolen door de fabrikant, gebruiken om het ontdooiproces te versnellen.

Koelcircuit niet beschadigen .

Gebruik geen elektrische apparaten binnen het voedsel opslag compartiment van het toestel, tenzij aanbevolen types door de fabrikant.



IN HET GEVAL DAT DE VOEDINGSKABEL IS BESCHADIGD, DE FABRIKANT OF DE AFTER-SALES SERVICE, OF GEKWALIFICEERDE TECHNICUS VERVANGEN. MET HET OOG OP EVENTUELE RISICO'S TE VOORKOMEN.

DE LAMP REPARATIE EN VERVANGING WORDEN UITGEVOERD DOOR GEKWALIFICEERDE TECHNICI WORDEN UITGEVOERD, MET VOEDING AFGEKOPPELD, TE VERVANGEN DOOR IDENTIEKE LAMPEN.

ALLEEN GEKWALIFICEERDE TECHNICI VOEREN DE BUITENGEWOON ONDERHOUD INTERVENTIES.



Verwijdering van verpakkingen

Alle verpakkingsmateriaal moet worden vernietigd in een milieuvriendelijke manier.

Het karton kan worden gebruikt als kladpapier. De beschermfolie en de schuimkussens CFK-vrij.

Laat kinderen niet spelen met de packageing en veilig vernietigen plastic zakken.

U kunt het karton in kleinere stukjes snijden of snijden en aan een afvalverwerkingsdienst geven.



Milieubescherming

Afgedankte elektrische apparaten zijn recyclebaar en mogen niet weggegooid worden in het huisvuil!

Wij vragen u ons steunen in behoud van hulpbronnen en de bescherming van het milieu door dit toestel terug naar de verzamelplaatsen (indien beschikbaar).



## Sicherheitshinweise

- Auf eine flache, stabile Fläche stellen.
- Alle erforderlichen Montage- und Reparaturarbeiten sollten von Wartungspersonal oder einem qualifizierten Techniker durchgeführt werden. Keine Bauteile oder Bedienflächen von diesem Produkt entfernen.
- Für folgende Normen und Vorschriften sind die lokalen und nationalen Normen heranzuziehen:
  - Arbeitsschutzvorschriften
  - BS EN Verhaltenspraktiken
  - Brandschutzvorschriften
  - IEE-Anschlussvorschriften
  - Bauvorschriften
- Das Gerät NICHT mit einem Strahl-/Hochdruckreiniger reinigen.
- Das Gerät NICHT zum Aufbewahren von medizinischen Produkten verwenden.
- KEINE Elektrogeräte im Gerät verwenden (wie Heizgeräte, Eiskremaschinen usw.).
- NICHT auf den Schrank, die Schubladen oder Türen stellen.
- KEIN ÖL oder Fett mit den Kunststoffteilen oder der Türdichtung in Kontakt kommen lassen. Bei Kontakt sofort reinigen.
- Nur zum Gebrauch in Gebäuden.
- Flaschen mit Alkohol in hoher Konzentration müssen dicht verschlossen und aufrecht stehend im Kühlschrank aufbewahrt werden.
- Das Gerät stets aufrecht tragen, lagern und transportieren, Zum Transport den Schrank an der Unterseite anfassen.
- Vor Reinigungsarbeiten stets zunächst das Gerät abschalten und den Netzstecker ziehen.
- Verpackungsmaterial außerhalb der Reichweite von Kindern aufbewahren und gemäß den lokalen Vorschriften entsorgen.
- Aus Sicherheitsgründen muss ein beschädigtes Stromkabel von einem Mitarbeiter oder empfohlenen qualifizierten Elektriker erneuert werden.

## Einführung

Bitte nehmen Sie sich einige Minuten Zeit und lesen Sie dieses Handbuch sorgfältig durch. Nur bei korrekter Wartung und vorschriftsgemäßem Betrieb kann Ihr Produkt optimale Leistung erzielen.

## Lieferumfang

Folgende Teile befinden sich in der Verpackung:

- Kühl- oder Tiefkühlgerät
- Schienen (2 pro Tür)
- Ablagen (1 pro Tür)
- Bedienungsanleitung

Wir sind stolz auf die hochwertige Qualität unserer Produkte und einen erstklassigen Service. Wir stellen sicher, dass alle gelieferten Produkte zum Zeitpunkt der Verpackung voll funktionsfähig sind und sich in einwandfreiem Zustand befinden. Sollten Sie Transportschäden feststellen, wenden Sie sich bitte unverzüglich an Ihren Händler.

## Montage

**Φ Hinweis: Wenn das Gerät nicht aufrecht transportiert oder gelagert wurde, muss es vor Inbetriebnahme rund 12 Stunden aufrecht aufgestellt werden. Im Zweifelsfall lassen Sie es aufrecht stehen.**

1. Gerät aus der Verpackung nehmen. Darauf achten, dass die gesamte Plastikfolie und alle Beschichtungen von sämtlichen Flächen entfernt wurden.
2. Zur Belüftung einen Abstand von 20 cm zwischen Gerät und Wänden oder anderen Objekten einhalten. Dieser Abstand muss größer sein, falls es sich bei dem Hindernis um eine Wärmequelle handelt.

**Φ Hinweis: Vor dem ersten Einsatz des Geräts die Ablagen und das Geräteinnere mit einer Seifenlauge reinigen.**

3. Die Bremsen an den Laufrollen feststellen, damit sich der Schrank nicht bewegen kann.
- ODER  
Das Gerät durch Einstellen der Schraubfüße ausgleichen.

## Befestigung der Ablagen

1. Einen Satz Ablageschienen auf beiden Schrankseiten in der gewünschten Höhe platzieren.
2. Die Ablage einschieben.
3. Wiederholen Sie das Verfahren für die übrigen Ablagen.

**Φ Hinweis: Die richtige Positionierung ist wichtig, damit Kondenswasser korrekt ablaufen kann.**

## Betrieb

### Lagerung von Nahrungsmitteln

Sie erzielen die besten Ergebnisse mit Ihrem Gerät, wenn Sie folgende Anweisungen beachten:

- Nahrungsmittel dürfen erst nach Erreichen der korrekten Betriebstemperatur im Gerät gelagert werden.
- Keine unbedeckten heißen Nahrungsmittel oder Flüssigkeiten in das Gerät legen oder stellen.
- Nahrungsmittel nach Möglichkeit einwickeln oder bedecken.
- Nicht die Lüfter im Gerät versperren.
- Türen nicht über längere Zeit geöffnet lassen.

### Einschalten

1. Die Tür(en) des Geräts schließen.
2. Darauf achten, dass der Ein-/Ausschalter auf [O] steht und der Netzstecker eingesteckt ist.
3. Das Gerät einschalten [I]. Die momentane Temperatur im Gerät wird angezeigt.

### Manuelles Abtauen

Das Gerät startet alle sechs Stunden automatisch einen Abtauzyklus.

**Φ Hinweis: Der Zyklus startet sechs Stunden nach dem ersten Anlaufen des Geräts.**

Manuelles Abtauen des Geräts:

1. Die Taste ABTAUEN  5 Sekunden lang gedrückt halten.
2. Der Abtauzyklus beginnt sofort und die Abtauanzeige leuchtet auf. Der Abtauzyklus dauert maximal 30 Minuten.

**Φ Hinweis: Durch das manuelle Abtauen wird der automatische Abtautimer zurückgesetzt.**

3. Der nächste automatische Abtauvorgang beginnt sechs Stunden nach Ende des manuellen Abtauens.

## Reinigung, Pflege und Wartung

- Vor Reinigungsarbeiten stets zunächst das Gerät abschalten und den Netzstecker ziehen.
- Den Schrank möglichst häufig innen reinigen.
- Keine Scheuermittel verwenden, da diese schädliche Rückstände hinterlassen können.
- Die Türdichtung nur mit Wasser reinigen.
- Nachdem Reinigen stets mit einem Tuch trocknen.
- Zur Reinigung verwendetes Wasser darf nicht durch die Ablauföffnung in die Auffangschale gelangen.
- Vorsicht beim Reinigen der Geräterückseite. Scharfe Kanten können zu Verletzungen führen.
- Erforderliche Reparaturen sollten von einem Mitarbeiter oder einem qualifizierten Techniker ausgeführt werden.

## Reinigen des Kondensators

Regelmäßiges Reinigen des Kondensators kann die Lebensdauer des Geräts verlängern.

Wir empfehlen, den Kondensator von einem Mitarbeiter oder qualifizierten Techniker reinigen zu lassen.

## Störungssuche

Bei einem Defekt Ihres Geräts konsultieren Sie bitte zunächst folgende Tabelle.

Störung	Vermutliche Ursache	Lösung
Das Gerät funktioniert nicht	Das Gerät ist nicht eingeschaltet	Prüfen, ob der Netzstecker in die Steckdose gesteckt wurde und das Gerät eingeschaltet ist
	Stecker und Kabel sind beschädigt	Mitarbeiter oder qualifizierten Techniker anrufen
	Sicherung im Stecker ist durchgebrannt	Neue Sicherung in den Stecker einsetzen
	Stromzufuhr	Netzstrom prüfen
	Interner Vernetzungsfehler	Mitarbeiter oder qualifizierten Techniker anrufen
Das Gerät lässt sich einschalten, aber die Temperatur ist zu hoch/ niedrig	Zu viel Eis auf dem Kondensator	Das Gerät abtauen
	Kondensator verstaubt	Mitarbeiter oder qualifizierten Techniker anrufen
	Türen sind nicht richtig geschlossen	Prüfen, ob die Türen geschlossen und die Dichtungen intakt sind
	Gerät befindet sich in der Nähe einer Wärmequelle, oder der Luftstrom zum Kondensator ist unterbrochen	Den Kühlschrank an einem geeigneteren Ort aufstellen
	Umgebungstemperatur ist zu hoch	Belüftung intensivieren oder Gerät an einem kühleren Ort aufstellen
	Ungeeignete Nahrungsmittel werden im Gerät aufbewahrt	Einige heiße Nahrungsmittel herausnehmen oder Produkte, die den Lüfter blockieren, entfernen
Aus dem Gerät läuft Wasser aus	Gerät ist überlastet	Weniger Nahrungsmittel im Gerät lagern
	Das Gerät steht nicht gerade	Die Schraubfüße so regulieren, dass das Gerät eben steht (sofern zutreffend)
	Der Ablauf ist verstopft	Den Ablauf säubern
	Wasser kann nicht ablaufen	Den Boden des Geräts von Fremdstoffen reinigen (sofern zutreffend)
	Der Wasserbehälter ist beschädigt	Mitarbeiter oder qualifizierten Techniker anrufen
Das Gerät ist ungewöhnlich laut	Die Tropfschale fließt über	Die Tropfschale leeren (sofern zutreffend)
	Der Sicherheitsriemen wurde nicht entfernt	Den Sicherheitsriemen entfernen
	Alle Muttern und Schrauben überprüfen und anziehen	Alle Muttern und Schrauben überprüfen und anziehen

## Technische spezifikationen(Weitere Details siehe Beilage)(R290)

Modell	Spannung	Stromstärke	Temperaturbereich	Füllmenge (Liter)	Abmessungen h×b×t (mm)	Gewicht (Kg)
GN2100BT	220-240V 50Hz	3.0A	-10°C ~ -20°C	314 Vn:206	1360×700×860	97
GN3100BT	220-240V 50Hz	3.0A	-10°C ~ -20°C	465 Vn:309	1795×700×860	117
GN4100BT	220-240V 50Hz	4.0A	-10°C ~ -20°C	616 Vn:412	2230×700×860	146
GN2200BT	220-240V 50Hz	3.0A	-10°C ~ -20°C	314 Vn:206	1360×700×960	103
GN3200BT	220-240V 50Hz	3.0A	-10°C ~ -20°C	465 Vn:309	1795×700×960	130
GN4200BT	220-240V 50Hz	4.0A	-10°C ~ -20°C	616 Vn:412	2230×700×960	160
SNACK2100BT	220-240V 50Hz	3.0A	-10°C ~ -20°C	260 Vn:172	1360×600×860	86
SNACK3100BT	220-240V 50Hz	3.0A	-10°C ~ -20°C	386	1795×600×860	107
SNACK4100BT	220-240V 50Hz	4.0A	-10°C ~ -20°C	511 Vn:344	2230×600×860	133
SNAC2200BT	220-240V 50Hz	3.0A	-10°C ~ -20°C	260 Vn:172	1360×600×960	99
SNACK3200BT	220-240V 50Hz	3.0A	-10°C ~ -20°C	386 Vn:258	1795×600×960	120
SNACK4200BT	220-240V 50Hz	4.0A	-10°C ~ -20°C	511 Vn:344	2230×600×960	147
GN2100TN	220-240V 50Hz	1.2A	-2°C ~ +8°C	314 Vn:206	1360×700×860	93
GN2100TNG	220-240V 50Hz	1.2A	+2°C ~ +8°C	314	1360×700×860	98
GN2200TN	220-240V 50Hz	1.2A	-2°C ~ +8°C	314 Vn:206	1360×700×960	95
GN2200TNG	220-240V 50Hz	1.2A	+2°C ~ +8°C	314	1360×700×960	100
GN3100TN	220-240V 50Hz	1.2A	-2°C ~ +8°C	465 Vn:309	1795×700×860	114
GN3100TNG	220-240V 50Hz	1.2A	+2°C ~ +8°C	465	1795×700×860	126
GN3200TN	220-240V 50Hz	1.2A	-2°C ~ +8°C	465	1795×700×960	125
GN3200TNG	220-240V 50Hz	1.2A	+2°C ~ +8°C	465	1795×700×960	137
GN4100TN	220-240V 50Hz	1.3A	-2°C ~ +8°C	616 Vn:412	2230×700×860	138

Modell	Spannung	Stromstärke	Temperaturbereich	Füllmenge (Liter)	Abmessungen h×b×t (mm)	Gewicht (Kg)
GN4100TNG	220-240V 50Hz	1.3A	+2°C ~ +8°C	616	2230×700×860	150
GN4200TN	220-240V 50Hz	1.3A	-2°C ~ +8°C	616 Vn:412	2230×700×960	152
GN4200TNG	220-240V 50Hz	1.3A	+2°C ~ +8°C	616	2230×700×960	164
PA2100TN	220-240V 50Hz	1.2A	+2°C ~ +8°C	428 Vn:304	1510×800×860	105
PA2200TN	220-240V 50Hz	1.2A	+2°C ~ +8°C	428	1510×800×960	116
PA3100TN	220-240V 50Hz	1.3A	+2°C ~ +8°C	635 Vn:456	2020×800×860	132
PA3200TN	220-240V 50Hz	1.3A	+2°C ~ +8°C	635 Vn:456	2020×800×960	146
SNACK2100TN	220-240V 50Hz	1.2A	-2°C ~ +8°C	260	1360×600×860	81
SNACK2100TNG	220-240V 50Hz	1.2A	+2°C ~ +8°C	260	1360×600×860	95
SNACK2200TN	220-240V 50Hz	1.2A	-2°C ~ +8°C	260 Vn:172	1360×600×960	94
SNACK2200TNG	220-240V 50Hz	1.2A	+2°C ~ +8°C	260	1360×600×960	108
SNACK3100TN	220-240V 50Hz	1.2A	-2°C ~ +8°C	386 Vn:258	1795×600×860	102
SNACK3100TNG	220-240V 50Hz	1.2A	+2°C ~ +8°C	386	1795×600×860	116
SNACK3200TN	220-240V 50Hz	1.2A	-2°C ~ +8°C	386 Vn:258	1795×600×960	115
SNACK3200TNG	220-240V 50Hz	1.2A	+2°C ~ +8°C	386	1795×600×960	129
SNACK4100TN	220-240V 50Hz	1.3A	-2°C ~ +8°C	511	2230×600×860	126
SNACK4100TNG	220-240V 50Hz	1.3A	+2°C ~ +8°C	511	2230×600×860	130
SNACK4200TN	220-240V 50Hz	1.3A	-2°C ~ +8°C	511 Vn:344	2230×600×960	140
SNACK4200TNG	220-240V 50Hz	1.3A	+2°C ~ +8°C	511	2230×600×960	155
U-GN2100TN	220-240V 50Hz	1.2A	-2°C ~ +8°C	214 Vn:130	1360×700×650	80
U-GN2140TN	220-240V 50Hz	1.2A	-2°C ~ +8°C	214 Vn:130	1360×700×650	93
U-GN2100TNG	220-240V 50Hz	1.2A	-2°C ~ +8°C	214	1360×700×650	80
U-GN2140TNG	220-240V 50Hz	1.2A	-2°C ~ +8°C	214 Vn:130	1360×700×650	93

Modell	Spannung	Stromstärke	Temperaturbereich	Füllmenge (Liter)	Abmessungen h×b×t (mm)	Gewicht (Kg)
U-GN3100TN	220-240V 50Hz	1.2A	-2°C ~ +8°C	317 Vn:195	1795×700×650	104
U-GN3160TN	220-240V 50Hz	1.2A	-2°C ~ +8°C	317	1795×700×650	123
U-GN4100TN	220-240V 50Hz	1.3A	-2°C ~ +8°C	420 Vn:260	2230×700×650	125
U-GN4180TN	220-240V 50Hz	1.3A	-2°C ~ +8°C	420 Vn:260	2230×700×650	150
SH2000/700	220-240V 50Hz	1.3A	+2°C ~ +8°C	396	1360×700×1085	100
SH2000/800	220-240V 50Hz	1.3A	+2°C ~ +8°C	459	1510×800×1085	115
SH3000/700	220-240V 50Hz	1.3A	+2°C ~ +8°C	470	1795×700×1085	121
SH3000/800	220-240V 50Hz	1.3A	+2°C ~ +8°C	576	2020×800×1085	145
PZ1610TN	220-240V 50Hz	1.2A	+2°C ~ +8°C	221	1515×800×1000	256
PZ2600TN	220-240V 50Hz	1.2A	+2°C ~ +8°C	428 Vn:304	1510×800×1000	234
PH2610TN	220-240V 50Hz	1.2A	+2°C ~ +8°C	428	2025×800×1000	334
PZ3600TN	220-240V 50Hz	1.3A	+2°C ~ +8°C	635 Vn:456	2025×800×1000	294

## Elektroanschlüsse

Der Stecker muss in eine geeignete Steckdose gesteckt werden. Das Gerät ist wie folgt verdrahtet:

- Stromführender Leiter (braun) an Klemme **L**
- Neutralleiter (blau) an Klemme **N**
- Erdleiter (grün/gelb) an Klemme **E**

Das Gerät muss über eine spezielle Erdleitung geerdet werden.

Bei Fragen wenden Sie sich bitte an einen qualifizierten Elektriker.

Elektroisolierpunkte dürfen nicht blockiert werden. Bei einem Notstopp müssen diese Punkte jederzeit sofort zugänglich sein.

## Entsorgung

Gemäß EU-Vorschriften müssen Kühlprodukte von Fachunternehmen entsorgt werden, die alle Gase, Metall- und Kunststoffbauteile entfernen oder recyceln.

Ihre Kommunalverwaltung kann Sie über die Entsorgung Ihres Geräts informieren. Kommunalbehörden sind nicht verpflichtet, gewerbliche Kühlgeräte zu entsorgen. Sie können Sie jedoch über lokale Annahmestellen informieren, die diese Geräte entsorgen.

## Konformität

Alle Produkte werden strengen Tests unterzogen, um die Einhaltung von Normen und Spezifikationen internationaler und nationaler Behörden und unabhängiger Organisationen zu gewährleisten. Produkte dürfen durch folgendes Symbol gekennzeichnet werden.

**Das Kältemittel R600a und R290 wird im Kühlschrank benutzt**



### WARNUNG:

Lüftungsöffnungen im Gerätegehäuse oder in der eingebauten Struktur behalten, frei von Hindernissen.

Verwenden Sie keine mechanischen Vorrichtungen oder andere Mittel, um den Abtauvorgang zu beschleunigen, sonst werden sie von dem Hersteller empfohlen.

Keinen Kältemittelkreislauf beschädigen.

Verwenden Sie kein elektrisches Geräte in den Vorratsbehältern des Gerätes, es sei denn, sie sind vom Hersteller empfohlen.



FALLS DAS STROMVERSORGUNGSKABEL BESCHADIGT IST, MUSS DER HERSTELLER ODER DER KUNDENDIENST ODER DER QUALIFIZIERTE TECHNIKER DAS STROMVERSORGUNGSKABEL ERSETZEN, UM EIN EVENTUELLES RISIKO ZU VERMEIDEN.

DIE REPARATUR UND DER AUSTAUSCH DER LAMPE MÜSSEN VON DEN QUALIFIZIERTEN TECHNIKERN DURCHFÜHRT WERDEN, WENN DIE STROMVERSORGUNG UNTERBROCHEN IST, UM MIT DEN IDENTISCHEN LAMPEN ZU ERSETZEN.

NUR DIE QUALIFIZIERTEN TECHNIKER FÜHREN DIE AUSSERORDENTLICHEN INSTANDHALTUNGSMASSNAHMEN DURCH.



Entsorgung von Verpackungen

Alle Verpackungsmaterialien sollten umweltgerecht entsorgt werden.

Der Karton kann als Schmierpapier verwendet werden. Die Schutzfolie und die Schaumstoffkissen sind CFC-frei.

Lassen Sie die Kinder nicht mit der Verpackung und Plastiktüten spielen.

Sie können den Karton in kleinere Stücke zerlegen oder schneiden, um als Papierabfall zur Verfügung zu stellen.



Umweltschutz

Die weggeworfenen Elektrogeräte sind recycelbar und sollten nicht im Hausmüll entsorgt werden! Bitte aktiv bei der Ressourcenschonung unterstützen und dieses Gerät durch die Rücksendung an die Sammelstellen zum Schutz der Umwelt (falls vorhanden)



## Conselhos de segurança

- Colocar numa superfície plana e estável.
- Um agente de serviço/técnico qualificado deverá efectuar a instalação e quaisquer reparações, caso necessário. Não retirar qualquer componente ou painéis de serviço deste produto.
- Consultar e cumprir os regulamentos locais e nacionais no que diz respeito à:
  - Legislação de saúde e segurança no local de trabalho
  - Códigos de trabalho
  - Prevenção de incêndios
  - Normas para sistemas eléctricos IEE
  - Código de construção
- NÃO utilizar máquinas de limpeza a pressão/jacto para limpar o produto.
- NÃO utilize este produto para armazenar acessórios médicos.
- NÃO utilizar aparelhos eléctricos no interior deste produto (como por exemplo máquinas de fazer gelados, etc..)
- NÃO se apoiar ou colocar em cima da base, das prateleiras ou das portas.
- NÃO permitir o contacto de óleo ou gordura com componentes de plástico ou guarnições das portas. Limpar imediatamente se tal acontecer.
- Apenas adequado para uso dentro de casa ou estabelecimentos.
- Fechar garrafas com uma elevada percentagem de álcool e colocá-las verticalmente no frigorífico.
- Este produto deve ser transportado, armazenado e manuseado em posição vertical. Transporte segurando o produto pela base.
- Deve-se sempre desligar o aparelho e retirar a ficha da tomada antes de fazer a limpeza.
- Mantenha o material da embalagem fora do alcance de crianças. O material da embalagem é para ser deitado fora respeitando as regras das autoridades locais.
- A fim de evitar situações perigosas, a substituição dos cabos de alimentação danificados deve ser feita por um agente ou um técnico qualificado recomendado.

## Introdução

Por favor utilize o tempo necessário para ler atentamente este manual. Uma manutenção e utilização correcta deste aparelho permitem a melhor capacidade de funcionamento do seu produto.

## Conteúdo da embalagem

A embalagem inclui o seguinte:

- Frigorífico ou congelador
- Suportes de prateleiras (2 por porta)
- Prateleiras (1 por porta)
- Manual de instruções

A orgulha-se pelo serviço e a qualidade dos seus produtos e portanto verifica, durante a fase de embalagem, o estado funcional e o bom estado do conteúdo fornecido.

Quando confrontado com quaisquer danos provocados durante o transporte, contacte imediatamente o seu fornecedor.

## Instalação

**Φ Nota: se o aparelho foi armazenado ou transportado numa posição não igual à posição de instalação, deve-se, antes de utilizar o mesmo, colocar o produto durante 12 horas na posição de instalação. Em caso de dúvida deve cumprir a instrução anterior.**

1. Retire o produto da embalagem. Verifique se retirou todas as tiras e camadas de protecção das superfícies do produto.
2. Para a ventilação adequada deve-se manter uma distância de 20cm entre o produto e as paredes ou outros objectos. Aumente esta distância se o objecto vizinho for uma fonte de calor.

**Φ Nota: Antes de utilizar o produto pela primeira vez deve ro limpar as prateleiras e o interior com água de sabão.**

3. Aplique os travões para manter o produto no lugar ou ajuste os pés reguláveis para nivelar o produto.

## Colocar as prateleiras

Coloque um par de suportes de prateleiras em ambos os lados do interior do produto e à altura desejada.

Coloque a prateleira no lugar.

Repetir esta instrução para colocar as outras prateleiras.

**Φ Nota: isto é muito importante para garantir uma drenagem correcta de condensação.**

## Funcionamento

### Armazenamento de produtos alimentares

Siga as seguintes instruções para obter os melhores resultados do seu produto:

- Deve-se apenas guardar alimentos no produto quando este tiver atingido a temperatura de funcionamento correcta.
- Não coloque comida quente ou líquidos destapados no produto.
- Quando possível tape ou embrulhe a comida.
- Não bloquear os ventiladores no interior do produto.
- Evite deixar as portas abertas durante muito tempo.

### Ligar

1. Feche a(s) porta(s) do produto.
2. Controle se o interruptor principal está na posição [O] e coloque a ficha do produto na tomada.
3. Ligue o Power (alimentação) [I]. a temperatura interna do produto é indicada no painel indicador

### Descongelamento manual

O produto iniciará automaticamente um ciclo de descongelamento de seis em seis horas.

⚠ **Nota: o ciclo inicia-se ao ligar o produto pela primeira vez.**

Para manualmente descongelar o produto:

1. Carregue e mantenha o botão DEFROST  pressionado durante 5 segundos.
2. O ciclo de descongelamento é imediatamente iniciado e o Defrost LED acende. O processo de descongelamento tem uma duração máxima de 30 minutos.

⚠ **Nota: ao iniciar um descongelamento manual o temporizador de descongelamento é automaticamente reiniciado. O próximo descongelamento automático iniciará seis horas depois da terminação do descongelamento manual.**

3. A água usada é recolhida no tabuleiro de água usada.

## Limpeza, cuidados & manutenção

- Deve-se desligar o aparelho e retirar a ficha da tomada antes de fazer a limpeza.
- Limpe o interior do produto com a máxima frequência possível.
- Não utilizar produtos de limpeza abrasivos. Estes podem deixar resíduos prejudiciais.
- Limpe as guarnições da porta apenas com água.
- Secar totalmente depois da limpeza.
- Não permitir que água utilizada para a limpeza entre na panela de evaporação através da abertura de drenagem.
- Tenha cuidado ao limpar a parte de trás do produto. Os cantos afiados podem cortar.
- Um agente da ou técnico qualificado deverá efectuar quaisquer reparações, caso necessário.

## Limpar o condensador

A limpeza com regularidade do condensador pode alargar a vida técnica do produto.

1. Recomenda que a limpeza do condensador seja efectuada por um agente ou técnico qualificado.

## Resolução de problemas

Se o seu produto apresentar uma falha, consulte a seguinte tabela antes.

Problema	Causa provável	A fazer
O aparelho não funciona	O aparelho não está ligado	Verifique a ligação correcta dos cabos e ligue o aparelho
	A ficha e o cabo estão danificados	Chame o agente da ou um técnico qualificado
	O fusível da ficha disparou	Substitua o fusível da ficha
	Fonte de alimentação	Verifique a fonte de alimentação
	Erro na cablagem interna	Chame o agente da ou um técnico qualificado
O produto liga mas a temperatura é demasiado alta ou baixa	Há muito gelo no condensador	Descongele o produto
	O condensador está bloqueado por pó	Chame o agente da ou um técnico qualificado
	As portas não estão totalmente fechadas	Verifique se as portas estão bem fechadas e se as guarnições estão danificadas
	O produto está perto de uma fonte de calor ou o fluxo de ar em direcção do condensador é interrompido	Desloque o frigorífico para um lugar mais adequado
	A temperatura ambiente é demasiado alta	Aumente a ventilação ou desloque o produto para uma posição mais fresca
	Está a guardar alimentos não adequados no produto	Retire quaisquer alimentos quentes ou alimentos que bloqueiem o ventilador
	O produto está sobrecarregado	Reduz a quantidade de alimentos armazenada no produto
Está a verter água do produto	O produto não está bem nivelado	Ajuste os pés reguláveis para nivelar o produto (caso necessário)
	A saída de descarga está bloqueada	Limpe a saída da descarga
	O movimento de água para a descarga está bloqueado	Limpe o chão do produto (caso aplicável)
	O recipiente de água está danificado	Chame o agente da ou um técnico qualificado
	O tabuleiro para gelo derretido (água) está a	Esvazie o tabuleiro (caso aplicável)

Problema	Causa provável	A fazer
O produto produz mais ruídos do que o normal	Não retirou a fita de segurança	Retire a fita de segurança
	Desaperte a porca/parafuso	Verifique e aperte todos os parafusos e porcas

## Especificações técnicas(Outros detalhes, veja a inserção)(R290)

Model	Voltagem	Corrente	Amplitude de temperatura	Capacidade e (litros)	Dimensões a×l×p (mm)	Peso (Kg)
GN2100BT	220-240V 50Hz	3.0A	-10°C ~ -20°C	314 Vn:206	1360×700×860	97
GN3100BT	220-240V 50Hz	3.0A	-10°C ~ -20°C	465 Vn:309	1795×700×860	117
GN4100BT	220-240V 50Hz	4.0A	-10°C ~ -20°C	616 Vn:412	2230×700×860	146
GN2200BT	220-240V 50Hz	3.0A	-10°C ~ -20°C	314 Vn:206	1360×700×960	103
GN3200BT	220-240V 50Hz	3.0A	-10°C ~ -20°C	465 Vn:309	1795×700×960	130
GN4200BT	220-240V 50Hz	4.0A	-10°C ~ -20°C	616 Vn:412	2230×700×960	160
SNACK2100BT	220-240V 50Hz	3.0A	-10°C ~ -20°C	260 Vn:172	1360×600×860	86
SNACK3100BT	220-240V 50Hz	3.0A	-10°C ~ -20°C	386	1795×600×860	107
SNACK4100BT	220-240V 50Hz	4.0A	-10°C ~ -20°C	511 Vn:344	2230×600×860	133
SNAC2200BT	220-240V 50Hz	3.0A	-10°C ~ -20°C	260 Vn:172	1360×600×960	99
SNACK3200BT	220-240V 50Hz	3.0A	-10°C ~ -20°C	386 Vn:258	1795×600×960	120
SNACK4200BT	220-240V 50Hz	4.0A	-10°C ~ -20°C	511 Vn:344	2230×600×960	147
GN2100TN	220-240V 50Hz	1.2A	-2°C ~ +8°C	314 Vn:206	1360×700×860	93
GN2100TNG	220-240V 50Hz	1.2A	+2°C ~ +8°C	314	1360×700×860	98
GN2200TN	220-240V 50Hz	1.2A	-2°C ~ +8°C	314 Vn:206	1360×700×960	95
GN2200TNG	220-240V 50Hz	1.2A	+2°C ~ +8°C	314	1360×700×960	100
GN3100TN	220-240V 50Hz	1.2A	-2°C ~ +8°C	465 Vn:309	1795×700×860	114
GN3100TNG	220-240V 50Hz	1.2A	+2°C ~ +8°C	465	1795×700×860	126
GN3200TN	220-240V 50Hz	1.2A	-2°C ~ +8°C	465	1795×700×960	125

Model	Voltagem	Corrente	Amplitude de temperatura	Capacidade e (litros)	Dimensões a×l×p (mm)	Peso (Kg)
GN3200TNG	220-240V 50Hz	1.2A	+2°C ~ +8°C	465	1795×700×960	137
GN4100TN	220-240V 50Hz	1.3A	-2°C ~ +8°C	616	2230×700×860	138
GN4100TNG	220-240V 50Hz	1.3A	+2°C ~ +8°C	616	2230×700×860	150
GN4200TN	220-240V 50Hz	1.3A	-2°C ~ +8°C	616 Vn:412	2230×700×960	152
GN4200TNG	220-240V 50Hz	1.3A	+2°C ~ +8°C	616	2230×700×960	164
PA2100TN	220-240V 50Hz	1.2A	+2°C ~ +8°C	428 Vn:304	1510×800×860	105
PA2200TN	220-240V 50Hz	1.2A	+2°C ~ +8°C	428 Vn:304	1510×800×960	116
PA3100TN	220-240V 50Hz	1.3A	+2°C ~ +8°C	635 Vn:456	2020×800×860	132
PA3200TN	220-240V 50Hz	1.3A	+2°C ~ +8°C	635	2020×800×960	146
SNACK2100TN	220-240V 50Hz	1.2A	-2°C ~ +8°C	260 Vn:172	1360×600×860	81
SNACK2100TNG	220-240V 50Hz	1.2A	+2°C ~ +8°C	260	1360×600×860	95
SNACK2200TN	220-240V 50Hz	1.2A	-2°C ~ +8°C	260	1360×600×960	94
SNACK2200TNG	220-240V 50Hz	1.2A	+2°C ~ +8°C	260	1360×600×960	108
SNACK3100TN	220-240V 50Hz	1.2A	-2°C ~ +8°C	386 Vn:258	1795×600×860	102
SNACK3100TNG	220-240V 50Hz	1.2A	+2°C ~ +8°C	386	1795×600×860	116
SNACK3200TN	220-240V 50Hz	1.2A	-2°C ~ +8°C	386 Vn:258	1795×600×960	115
SNACK3200TNG	220-240V 50Hz	1.2A	+2°C ~ +8°C	386	1795×600×960	129
SNACK4100TN	220-240V 50Hz	1.3A	-2°C ~ +8°C	511 Vn:344	2230×600×860	126
SNACK4100TNG	220-240V 50Hz	1.3A	+2°C ~ +8°C	511	2230×600×860	130
SNACK4200TN	220-240V 50Hz	1.3A	-2°C ~ +8°C	511	2230×600×960	140
SNACK4200TNG	220-240V 50Hz	1.3A	+2°C ~ +8°C	511	2230×600×960	155
U-GN2100TN	220-240V 50Hz	1.2A	-2°C ~ +8°C	214 Vn:130	1360×700×650	80
U-GN2140TN	220-240V 50Hz	1.2A	-2°C ~ +8°C	214	1360×700×650	93

Model	Voltagem	Corrente	Amplitude de temperatura	Capacidade e (litros)	Dimensões a×l×p (mm)	Peso (Kg)
U-GN3100TN	220-240V 50Hz	1.2A	-2°C ~ +8°C	317 Vn:195	1795×700×650	104
U-GN3160TN	220-240V 50Hz	1.2A	-2°C ~ +8°C	317 Vn:195	1795×700×650	123
U-GN4100TN	220-240V 50Hz	1.3A	-2°C ~ +8°C	420 Vn:260	2230×700×650	125
U-GN4180TN	220-240V 50Hz	1.3A	-2°C ~ +8°C	420 Vn:260	2230×700×650	150
SH2000/700	220-240V 50Hz	1.3A	+2°C ~ +8°C	396	1360×700×1085	100
SH2000/800	220-240V 50Hz	1.3A	+2°C ~ +8°C	459	1510×800×1085	115
SH3000/700	220-240V 50Hz	1.3A	+2°C ~ +8°C	470	1795×700×1085	121
SH3000/800	220-240V 50Hz	1.3A	+2°C ~ +8°C	576	2020×800×1085	145
PZ1610TN	220-240V 50Hz	1.2A	+2°C ~ +8°C	221	1515×800×1000	256
PZ2600TN	220-240V 50Hz	1.2A	+2°C ~ +8°C	428	1510×800×1000	234
PH2610TN	220-240V 50Hz	1.2A	+2°C ~ +8°C	428 Vn:304	2025×800×1000	334
PZ3600TN	220-240V 50Hz	1.3A	+2°C ~ +8°C	635 Vn:456	2025×800×1000	294

## Cablagem elétrica

Deve-se utilizar tomadas adequadas para ligar a ficha do aparelho. O esquema de electricidade deste aparelho é o seguinte:

- Cabo eléctrico (castanho) para o terminal marcado **L**
- Cabo neutro (azul) para p terminal marcado **N**
- Cabo terra (verde/amarelo) para p terminal marcado com **E**

Este aparelho tem que estar ligado à terra através de um circuito de terra. Consulte um electricista qualificado em caso de dúvidas

Os pontos eléctricos isolados devem ficar limpos de qualquer obstrução. Estes pontos têm que ser imediatamente acessíveis caso seja necessário desligar a electricidade.

## Tratamento de lixo e resíduos

Os regulamentos da UE exigem a entrega de produtos de refrigeração a empresas especializadas em remover ou reciclar todos os gases, metais e componentes de plástico. Consulte a autoridade responsável pelo tratamento de lixo sobre a recolha do seu aparelho. As autoridades locais não são responsáveis pela recolha de equipamento comercial de refrigeração, no entanto, podem informá-lo quanto a recolha local do seu equipamento.

## Conformidade

As componentes foram submetidas a testes rigorosos a fim de cumprirem as normas e especificações legais determinadas pelas autoridades internacionais, independentes e nacionais.

Os produtos foram aprovados e trazem o seguinte símbolo.

**O refrigerante R600a e R290 é usado por este refrigerador**

**AVISO:**

Mantenha a ventilação aberta, no compartimento do aparelho ou na estrutura embutida, sem obstrução.

Não utilize dispositivos mecânicos ou outros meios para acelerar o processo de descongelação, salvo os recomendados pelo fabricante.

Não danifique o circuito de refrigeração.

Não utilize aparelhos eléctricos dentro dos compartimentos de armazenamento de alimentos do aparelho, a não ser que sejam do tipo recomendado pelo fabricante.



CASO O CABO DE ALIMENTAÇÃO ESTEJA DANIFICADO, O FABRICANTE OU O SERVIÇO PÓS-VENDA OU TÉCNICO QUALIFICADO DEVE SUBSTITUI-LO. FIM DE EVITAR QUALQUER RISCO.

A REPARAÇÃO E A SUBSTITUIÇÃO DA LÂMPADA DEVEM SER EFECTUADAS POR TÉCNICOS QUALIFICADOS, COM A ALIMENTAÇÃO DESLIGADA. SUBSTITUA POR LÂMPADAS IDÊNTICAS.

SOMENTE TÉCNICOS QUALIFICADOS DEVEM REALIZAR AS EXTRAORDINÁRIAS INTERVENÇÕES DE MANUTENÇÃO.

**Eliminação de embalagens**

Todos os materiais de embalagem devem ser eliminados de forma ecológica.

O cartão pode ser usado como papel de sucata. A película de protecção e as almofadas de espuma são CFC-gratuitas.

É proibido que as crianças brinquem com a embalagem e destruam os sacos de plástico com segurança.

Pode quebrar ou cortar o papelão em pedaços menores e dar a um serviço de eliminação de maculaturas.

**Protecção ambiental**

Eletrodomésticos descartados são recicláveis e não devem ser descartados no lixo doméstico! Por favor, apoie-nos ativamente na conservação de recursos e na protecção do ambiente, devolvendo este aparelho aos centros de recolha (se for disponível).



## Меры предосторожности

- Установление на плоской, твердой поверхности.
- Установка и ремонт должны быть проводиться сервисной службой или квалифицированным технологом. Не удаляйте никакие детали или сервисные панели на этом продукте.
- Проверьте соответствие продукта Местному или Национальному стандарту по следующим пунктам:
  - Здоровье и безопасность труда
  - Свод правил BS EN
  - Пожарная безопасность
  - Требования к электропроводке IEE
  - Строительные нормы и правила
- Не применяйте для очищения оборудования аппараты, работающие под давлением.
- Не предназначено для использования на улице.
- Не предназначено для хранения медикаментов.
- Не используйте электрические приспособления внутри оборудования (например нагреватели, мороженицы и др.).
- Не становитесь и не облакачивайтесь на основание, дверцы или ящики.
- Не допускайте контактирования масла или жира с пластиковыми компонентами и дверными уплотнителями. Немедленно очистите поверхность в случае попадания.
- Бутылки, содержащие алкоголь большой крепости должны быть запечатаны и поставлены в холодильник вертикально.
- Всегда переносите, устанавливайте и используйте оборудование в вертикальном положении и передвигайте, держась за основание.
- Всегда выключайте и обесточивайте оборудование перед его очищением.
- Держите все компоненты комплектации в безопасном от детей месте, а в случае утилизации действуйте в соответствии с местными требованиями по утилизации оборудования.
- В случае повреждения шнура питания, он может быть заменен в сервисном центре или рекомендованным квалифицированным технологом для исключения возможного риска.

## Введение

Пожалуйста, уделите несколько минут и внимательно прочтите это руководство. Правильная эксплуатация и уход обеспечит бесперебойную работу этого оборудования.

## Комплектация

В комплектацию включается:

- Холодильник или морозильник
- Направляющие для полок (2шт. на каждую дверь)
- Полки (1шт. на каждую дверь)
- Руководство по использованию

Мы гордимся качеством и сервисом своего оборудования и гарантируем, что на момент упаковки все комплектующие находятся в рабочем состоянии и не имеют повреждений.

Если вы обнаружили какие-либо повреждения после транспортировки, пожалуйста, немедленно свяжитесь

в Вашем диллере.

## Установка

**Ф Внимание:** Если устройство не хранилось или не переносилось вертикально, перед началом использования оставьте его в вертикальном положении приблизительно на 12 часов. Если Вы не уверены в каком положении хранилось или переносилось устройство, также оставьте его на в вертикальном положении на 12 часов.

1. Извлеките аппарат из упаковки. Удостоверьтесь в том, что защитная пластиковая пленка и защитное покрытие удалено со всех поверхностей.
2. Держите устройство на расстоянии не менее 20 см от стены или других предметов для правильного вентилирования. Увеличьте расстояние, если препятствие является источником тепла.

**Ф Внимание:** Перед первичным использованием оборудования промойте полки и внутренние поверхности мыльной водой.

3. Поставьте колесики на тормоз для фиксации положения или отрегулируйте ножки по высоте.

## Установка полок

1. Установите 1 комплект направляющих для полок по обеим сторонам холодильного аппарата на необходимой Вам высоте.
2. Плавнo задвиньте полку.
3. Повторите всю процедуру для оставшихся полок.

## Эксплуатация

### Хранение продуктов

Для наилучшего использования оборудования, следуйте данной инструкции:

- Размещайте продукты только после того, как будет достигнута рабочая температура.
- Не размещайте незакрытые горячие продукты или жидкости внутри аппарата.
- По возможности заворачивайте или накрывайте продукты.
- Не преграждайте вентиляцию внутри аппарата.
- Старайтесь не оставлять двери открытыми в течение длительного времени.

## Включение

- Закройте двери.
- Убедитесь, что выключатель находится в положении [O] и включите в розетку.

Приведите в действие путем переключения выключателя в положение [I]. Температура внутри аппарата указывается на электронном дисплее.

## Принудительное размораживание

Цикл разморозки включается автоматически каждые 6 часов

**Ф Внимание: Цикл отсчитывается с момента первичного включения оборудования**

Проведение разморозки вручную:

1. Нажмите и держите кнопку «defrost» в течение 5 секунд
2. Цикл разморозки начнется немедленно и включится светодиодная иллюминация. Максимальная длительность цикла – 30 минут

**Ф Внимание: С момента включения ручной разморозки, таймер авторазморозки перезагружается и начинает отсчет нового цикла.**

## Содержание и техническое обслуживание, уход и очищение

- Выключите аппарат и отключите от источника питания перед очисткой
- По необходимости промывайте внутреннюю часть оборудования.
- Не используйте абразивные очистители, они могут повредить поверхность.
- Дверные уплотнители промывайте только водой.
- После очистки аппарата всегда протирайте его насухо.
- Не допускайте протекания воды, используемой во время очистки, в канал для отвода воды в испарительный поддон.
- Будьте аккуратны при очищении задней поверхности оборудования, чтобы не пораниться об острые углы.
- По необходимости специалист сервисной службы или квалифицированный технолог должен проводить починку оборудования.

## Очищение конденсатора

Периодическая промывка конденсатора увеличивает срок службы оборудования.

Такую очистку не рекомендуется проводить самостоятельно, обратитесь к специалисту сервисной службы или другому квалифицированному технолог.

## Устранение неполадок

Если Вы заметили неполадки в работе устройства, пожалуйста, сверьтесь с данной таблицей, прежде чем Вы свяжитесь с диллером.

Неисправность	Возможная причина	Действие
Устройство не работает	Прибор не включен	Проверьте подключение к розетке и переключен ли выключатель в позицию [I]
	Вилка и подводящий провод повреждены	Свяжитесь с Вашим диллером или квалифицированным технологом
	Предохранитель оплавлен	Замените предохранитель
	Источник питания	Проверьте источник питания
	Проблемы с внутренней проводкой	Свяжитесь с Вашим диллером или квалифицированным технологом
Устройство включается, но температура слишком высокая/низкая	Намерзание слишком большого количества льда на испарителе	Разморозьте устройство
	Конденсатор заблокирован пылью	Свяжитесь с Вашим диллером или квалифицированным технологом
	Двери не полностью закрываются	Проверьте захлопнуты ли двери и не повреждены ли уплотнители
	Устройство расположено рядом с источником тепла или воздушный поток из конденсатора прегражден	Передвиньте холодильник в более подходящее место
	Температура окружающей среды слишком высока	Увеличьте вентиляцию помещения или передвиньте устройство в более подходящее место
	В холодильник помещено неподходящие продукты	Извлеките слишком горячие продукты или передвиньте продукты, блокирующие вентиляцию

Неисправность	Возможная причина	Действие
	Устройство перегружено	Уменьшите количество продуктов, расположенных в холодильнике
Наблюдается подтекание воды из устройства	Устройство не достаточно выровнено	По возможности отрегулируйте ножки по высоте путем их подкручивания
	Выходное отверстие заблокировано	Прочистите отверстие
	Прохождение воды к каналу для оттока затруднено	По возможности очистите дно устройства
	Поддон для воды поврежден	Свяжитесь с Вашим диллером или квалифицированным технологом
Устройство работает необычно шумно	Фиксирующая лента не была удалена	Удалите фиксирующую ленту и болты к ней
	Ослаблены болты/гайки	Проверьте хорошо ли закручены все болты
	Устройство не было установлено в устойчивую позицию или выровнено по горизонтали	Проверьте позицию устройства и измените, если необходимо

### Технические спецификации(Другие подробности см. Вставку)(R290)

Модель	Вольтаж	Ток	Температурный режим	Вместимость (литры)	Размеры В×Ш×Д	Масса (кг)
GN2100BT	220-240V 50Hz	3.0A	-10°C ~ -20°C	314 Vn:206	1360×700×860	97
GN3100BT	220-240V 50Hz	3.0A	-10°C ~ -20°C	465 Vn:309	1795×700×860	117
GN4100BT	220-240V 50Hz	4.0A	-10°C ~ -20°C	616 Vn:412	2230×700×860	146
GN2200BT	220-240V 50Hz	3.0A	-10°C ~ -20°C	314 Vn:206	1360×700×960	103
GN3200BT	220-240V 50Hz	3.0A	-10°C ~ -20°C	465 Vn:309	1795×700×960	130
GN4200BT	220-240V 50Hz	4.0A	-10°C ~ -20°C	616 Vn:412	2230×700×960	160
SNACK2100BT	220-240V 50Hz	3.0A	-10°C ~ -20°C	260 Vn:172	1360×600×860	86
SNACK3100BT	220-240V 50Hz	3.0A	-10°C ~ -20°C	386	1795×600×860	107
SNACK4100BT	220-240V 50Hz	4.0A	-10°C ~ -20°C	511 Vn:344	2230×600×860	133
SNAC2200BT	220-240V 50Hz	3.0A	-10°C ~ -20°C	260 Vn:172	1360×600×960	99
SNACK3200BT	220-240V 50Hz	3.0A	-10°C ~ -20°C	386 Vn:258	1795×600×960	120
SNACK4200BT	220-240V 50Hz	4.0A	-10°C ~ -20°C	511 Vn:344	2230×600×960	147
GN2100TN	220-240V 50Hz	1.2A	-2°C ~ +8°C	314 Vn:206	1360×700×860	93
GN2100TNG	220-240V 50Hz	1.2A	+2°C ~ +8°C	314	1360×700×860	98

Модель	Вольтаж	Ток	Температурный режим	Вместимость (литры)	Размеры В×Ш×Д	Масса (кг)
GN2200TN	220-240V 50Hz	1.2A	-2°C ~ +8°C	314 Vn:206	1360×700×960	95
GN2200TNG	220-240V 50Hz	1.2A	+2°C ~ +8°C	314	1360×700×960	100
GN3100TN	220-240V 50Hz	1.2A	-2°C ~ +8°C	465 Vn:309	1795×700×860	114
GN3100TNG	220-240V 50Hz	1.2A	+2°C ~ +8°C	465	1795×700×860	126
GN3200TN	220-240V 50Hz	1.2A	-2°C ~ +8°C	465	1795×700×960	125
GN3200TNG	220-240V 50Hz	1.2A	+2°C ~ +8°C	465	1795×700×960	137
GN4100TN	220-240V 50Hz	1.3A	-2°C ~ +8°C	616	2230×700×860	138
GN4100TNG	220-240V 50Hz	1.3A	+2°C ~ +8°C	616	2230×700×860	150
GN4200TN	220-240V 50Hz	1.3A	-2°C ~ +8°C	616 Vn:412	2230×700×960	152
GN4200TNG	220-240V 50Hz	1.3A	+2°C ~ +8°C	616	2230×700×960	164
PA2100TN	220-240V 50Hz	1.2A	+2°C ~ +8°C	428 Vn:304	1510×800×860	105
PA2200TN	220-240V 50Hz	1.2A	+2°C ~ +8°C	428 Vn:304	1510×800×960	116
PA3100TN	220-240V 50Hz	1.3A	+2°C ~ +8°C	635 Vn:456	2020×800×860	132
PA3200TN	220-240V 50Hz	1.3A	+2°C ~ +8°C	635	2020×800×960	146
SNACK2100TN	220-240V 50Hz	1.2A	-2°C ~ +8°C	260 Vn:172	1360×600×860	81
SNACK2100TNG	220-240V 50Hz	1.2A	+2°C ~ +8°C	260	1360×600×860	95
SNACK2200TN	220-240V 50Hz	1.2A	-2°C ~ +8°C	260	1360×600×960	94
SNACK2200TNG	220-240V 50Hz	1.2A	+2°C ~ +8°C	260	1360×600×960	108
SNACK3100TN	220-240V 50Hz	1.2A	-2°C ~ +8°C	386 Vn:258	1795×600×860	102
SNACK3100TNG	220-240V 50Hz	1.2A	+2°C ~ +8°C	386	1795×600×860	116
SNACK3200TN	220-240V 50Hz	1.2A	-2°C ~ +8°C	386 Vn:258	1795×600×960	115
SNACK3200TNG	220-240V 50Hz	1.2A	+2°C ~ +8°C	386	1795×600×960	129
SNACK4100TN	220-240V 50Hz	1.3A	-2°C ~ +8°C	511 Vn:344	2230×600×860	126

Модель	Вольтаж	Ток	Температурный режим	Вместимость (литры)	Размеры В×Ш×Д	Масса (кг)
SNACK4100TNG	220-240V 50Hz	1.3A	+2°C ~ +8°C	511	2230×600×860	130
SNACK4200TN	220-240V 50Hz	1.3A	-2°C ~ +8°C	511	2230×600×960	140
SNACK4200TNG	220-240V 50Hz	1.3A	+2°C ~ +8°C	511	2230×600×960	155
U-GN2100TN	220-240V 50Hz	1.2A	-2°C ~ +8°C	214 Vn:130	1360×700×650	80
U-GN2140TN	220-240V 50Hz	1.2A	-2°C ~ +8°C	214	1360×700×650	93
U-GN3100TN	220-240V 50Hz	1.2A	-2°C ~ +8°C	317 Vn:195	1795×700×650	104
U-GN3160TN	220-240V 50Hz	1.2A	-2°C ~ +8°C	317 Vn:195	1795×700×650	123
U-GN4100TN	220-240V 50Hz	1.3A	-2°C ~ +8°C	420 Vn:260	2230×700×650	125
U-GN4180TN	220-240V 50Hz	1.3A	-2°C ~ +8°C	420 Vn:260	2230×700×650	150
SH2000/700	220-240V 50Hz	1.3A	+2°C ~ +8°C	396	1360×700×1085	100
SH2000/800	220-240V 50Hz	1.3A	+2°C ~ +8°C	459	1510×800×1085	115
SH3000/700	220-240V 50Hz	1.3A	+2°C ~ +8°C	470	1795×700×1085	121
SH3000/800	220-240V 50Hz	1.3A	+2°C ~ +8°C	576	2020×800×1085	145
PZ1610TN	220-240V 50Hz	1.2A	+2°C ~ +8°C	221	1515×800×1000	256
PZ2600TN	220-240V 50Hz	1.2A	+2°C ~ +8°C	428	1510×800×1000	234
PH2610TN	220-240V 50Hz	1.2A	+2°C ~ +8°C	428 Vn:304	2025×800×1000	334
PZ3600TN	220-240V 50Hz	1.3A	+2°C ~ +8°C	635 Vn:456	2025×800×1000	294

## Электропроводка

Устройство поставляется в комплектации с 2х штифтовой штепсельной вилкой, подводящим шнуром и стандартным предохранителем.

Вилка должна быть подключена к подходящей розетке

В устройство вмонтированы следующие провода:

- Провод под напряжением (коричневого цвета) к клемме **L**
- Нулевой провод (синего цвета) к клемме **M**
- Заземляющий провод (зеленого или желтого цвета) к клемме **E**

Устройство должно быть заземлено, используя предназначенный для этого заземляющий контур.

В случае возникновения сомнений, обратитесь к квалифицированному электрику.

Места электрической изоляции должны быть абсолютно свободны для доступа на случай необходимости экстренного обесточивания.

## Утилизация

В соответствии с нормами ЕС требуется устранение (утилизация) продукта специалистом компании, который удалит или переработает все газы, металл и пластиковые детали.

Проконсультируйтесь с местным представителем органа по утилизации отходов касательно Вашего оборудования.

Данный орган не обязан утилизировать технологическое холодильное оборудование, однако, возможно, Вам посоветуют службу, в которую можно обратиться.

## Соответствие техническим требованиям

Детали были подвергнуты тестированию на предмет соответствия стандартам, установленным международными, независимыми и федеральными властями.

Продукт соответствует стандартам и одобрен для выпуска под следующим знаком.

**В данном устройстве используется холодильный агент R600a и R290**



### ВНИМАНИЕ!

Не закрывайте вентиляционные отверстия в корпусе устройства или во встроенной системе.

Не используйте механические устройства или другие средства для ускорения размораживания, кроме рекомендованных производителем.

Не повреждайте систему циркуляции холодильного агента.

Не используйте электрические приборы, кроме рекомендованных производителем, внутри отделений для хранения продуктов.



**В СЛУЧАЕ ПОВРЕЖДЕНИЯ КАБЕЛЯ ЭЛЕКТРОПИТАНИЯ ПРОИЗВОДИТЕЛЬ, СЛУЖБА СЕРВИСНОГО ОБСЛУЖИВАНИЯ ИЛИ КВАЛИФИЦИРОВАННЫЙ ТЕХНИК ДОЛЖНЫ ЗАМЕНИТЬ КАБЕЛЬ В ЦЕЛЯХ ПРЕДОТВРАЩЕНИЯ ВОЗМОЖНЫХ РИСКОВ.**

**РЕМОНТ И ЗАМЕНА ЛАМПЫ ДОЛЖНА ПРОИЗВОДИТЬСЯ КВАЛИФИЦИРОВАННЫМ ТЕХНИКОМ ПРИ УСТРОЙСТВЕ, ОТКЛЮЧЕННЫМ ОТ ИСТОЧНИКА ПИТАНИЯ. ПРИ ЗАМЕНЕ ИСПОЛЬЗУЮТСЯ ИДЕНТИЧНЫЕ ЛАМПЫ.**

**ВНЕПЛАНОВЫЕ ОПЕРАЦИИ ПО ТЕХНИЧЕСКОМУ ОБСЛУЖИВАНИЮ ДОЛЖНЫ ПРОВОДИТЬСЯ ТОЛЬКО КВАЛИФИЦИРОВАННЫМ ТЕХНИКОМ.**



### Утилизация упаковки

Все упаковочные материалы должны быть утилизированы экологически безопасными способами.

Картон можно утилизировать как макулатуру. Защитная фольга и пенные прокладки не содержат хлорфторуглеродов.

Не разрешайте детям играть с упаковкой и утилизируйте пластиковые мешки безопасным способом.

Вы можете разломать или разрезать картонную упаковку на меньшие части и сдать в центр утилизации бумажных отходов.



### Охрана окружающей среды

Заброшенные электрического оборудования могут быть переработаны и не создается непосредственно в мусорное ведро! Пожалуйста, активно поддержите нашу работу по охране окружающей среды и отправьте эту устаревшее оборудование в центр утилизации отходов (если есть)

## Güvenlik İpuçları

- Düz ve sabit bir yüzeye yerleştirin.
- Bir servis temsilcisi/kalifiye teknisyen, gerekirse montajı ve onarımları gerçekleştirmelidir. Bu üründeki hiçbir bileşeni veya servis panelini çıkarmayın.
- Aşağıdakilere uymak için Yerel ve Ulusal Standartlara bakın:
- İş Sağlığı ve Güvenliği Mevzuatı
- BS EN Uygulama Kodları
- Yangın Önlemleri
- IEE Kablolama Yönetmelikleri
- Bina Yönetmelikleri
- Cihazı temizlemek için jet/basınçlı yıkayıcılar KULLANMAYIN.
- Cihazı dışarıda KULLANMAYIN.
- Bu cihazı tıbbi malzemeleri saklamak için KULLANMAYIN.
- Cihazın içinde elektrikli cihazlar KULLANMAYIN (örneğin ısıtıcılar, dondurma makineleri vb.)
- Taban, çekmeceler veya kapılar üzerinde durmayın veya kendinizi desteklemeyin.
- Yağ veya katı yağın plastik bileşenlerle veya kapı contasıyla temas etmesine İZİN VERMEYİN. Temas olursa hemen temizleyin.
- Yüksek oranda alkol içeren şişeler kapatılmalı ve buzdolabına dikey olarak yerleştirilmelidir. • Cihazı her zaman dikey konumda taşıyın, saklayın ve tutun ve cihazın tabanından tutarak hareket ettirin.
- Temizlemeden önce her zaman üniteye gelen güç kaynağını kapatın ve bağlantısını kesin.
- Tüm ambalajları çocuklardan uzak tutun. Ambalajı yerel makamların düzenlemelerine uygun şekilde atın.
- Güç kablosu hasarlıysa, tehlikeyi önlemek için bir acente veya önerilen kalifiye bir teknisyen tarafından değiştirilmelidir.
- Bu ünite, 8 yaş üstü çocuklar ve fiziksel, duyuşsal veya zihinsel yetenekleri azalmış veya deneyim ve bilgisi eksik olan, cihazın kullanımı konusunda gözetim veya talimat verilmiş ve ortaya çıkan riskleri anlayan kişiler tarafından kullanılabilir (Avrupa pazarı için).
- Bu cihaz, güvenliklerinden sorumlu bir kişi tarafından cihazın kullanımıyla ilgili gözetim veya talimat verilmediği sürece fiziksel, duyuşsal veya zihinsel yetenekleri azalmış veya deneyim ve bilgisi eksik olan kişiler (çocuklar dahil) tarafından kullanılmak üzere tasarlanmamıştır (Avrupa dışındaki pazarlar için).
- Çocukların cihazla oynamamalarını sağlamak için gözetim altında tutulmaları gerekir.
- Çalışma istasyonundaki ses basınç seviyesi 70 dB'nin çok altındadır.
- Her tip rafın maksimum yükleme kapasitesi: 20 Kg.

## Giriş

Lütfen bu kılavuzu dikkatlice okumak için birkaç dakikanızı ayırın. Bu makinenin doğru bakımı ve işletimi, ürününüzden mümkün olan en iyi performansı almanızı sağlayacaktır..

## Ambalaj İcerigi

- Aşağıdakiler dahildir:
- 
- Buzdolabı veya Dondurucu
- Raf kılavuzları (kapı başına 2)
- Raflar (kapı başına 1)
- Kullanım kılavuzu

Kalite ve hizmetlerimizle gurur duyuyoruz, paketleme sırasında içeriklerin tamamen işlevsel ve hasarsız bir şekilde teslim edilmesini sağlıyoruz.

Nakliye sonucu herhangi bir hasar bulursanız lütfen hemen bayinizle iletişime geçin.

## Kurulum

- **Φ Not:** Ünite dik bir pozisyonda saklanmamış veya hareket ettirilmemişse, çalıştırmadan önce yaklaşık 12 saat dik durmasını sağlayın. Şüphemiz varsa, dik durmasına izin verin.
- 1. Cihazı ambalajından çıkarın. Tüm koruyucu plastik film ve kaplamaların tüm yüzeylerden iyice çıkarıldığından emin olun.
- 2. Havalandırma için ünite ile duvarlar veya diğer nesnelere arasında 20 cm (7 inç) mesafe bırakın. Engel bir ısı kaynağıysa bu mesafeyi artırın.
- **Φ Not:** Cihazı ilk kez kullanmadan önce rafları ve iç kısmı sabunlu suyla temizleyin.
- 3. Cihazı yerinde tutmak için tekerleklerdeki frenleri ayarlayın VEYA

- Vida ayaklarını ayarlayarak cihazı dengeleyin.

## Rafların Takılması

4. Raf kılavuzlarından bir setini dolabın her iki tarafına istediğiniz yükseklikte yerleştirin.
5. Rafı yerine kaydırın.
6. Kalan raflar için tekrarlayın.

⊕ **Note: Bu, yoğunluğun doğru şekilde tahliye edilmesini sağlamak için hayati önem taşır.**

## Operasyon

### Yiyeceklerin Saklanması

Cihazınızdan en iyi sonuçları almak için şu talimatları izleyin:

- 1-Gıda maddelerini yalnızca cihaz doğru çalışma sıcaklığına ulaştığında cihaza koyun.
- 2- Cihazın içine açıkta sıcak yiyecek veya sıvı koymayın.
- 3- Mümkünse yiyecekleri sarın veya örtün.
- 4- Cihazın içindeki fanları engellemeyin.
- 5- Kapıları uzun süre açmaktan kaçının.

### Açma / Çalıştırma

Cihazın kapağını/kapılarını kapatın.

Güç anahtarının [O] konumuna ayarlandığından ve prizden açıldığından emin olun.

Güçü açın [I]. Cihazın içindeki mevcut sıcaklık görüntülenir.

### Manuel Buz Çözme

Cihaz her altı saatte bir otomatik olarak bir buz çözme döngüsü çalıştıracaktır.

⊕ Not: Döngü, cihaz ilk kez çalıştırıldığı andan itibaren başlar.

Cihazı manuel olarak buz çözmek için:

1. DEFROST düğmesini 5 saniye basılı tutun.
  2. Buz çözme döngüsü hemen başlayacak ve Buz Çözme LED'i yanacaktır. Buz çözme en fazla 30 dakika sürecektir.
- ⊕ Not: Manuel buz çözmeyi başlatmak, manuel buz çözme zamanlayıcısını da sıfırlar. Bir sonraki otomatik buz çözme, manuel buz çözme bittikten altı saat sonra başlayacaktır.

Atık su, atık su tepsisinde toplanır.

### Temizlik, Bakım ve Onarım

- Temizlik, Bakım ve Onarım
- Temizlemeden önce kapatın ve güç kaynağından ayırın.
- Cihazın içini mümkün olduğunca sık temizleyin.
- Aşındırıcı temizlik maddeleri kullanmayın. Bunlar zararlı kalıntılar bırakabilir.
- Kapı contasını sadece suyla temizleyin.
- Temizlikten sonra her zaman kurulayın.
- Temizlikte kullanılan suyun tahliye deliğinden buharlaşma kabına akmasına izin vermeyin.
- Cihazın arkasını temizlerken dikkatli olun. Keskin kenarlar kesebilir.
- Gerekirse bir acente veya kalifiye teknisyen onarımları gerçekleştirmelidir..

### Kondanserin Temizliği

- Kondansatörün periyodik olarak temizlenmesi cihazın ömrünü uzatabilir.

**Kondansatörün acentemiz veya kalifiye teknisyenimiz tarafından temizlenmesini öneririz**

## Sorun Giderme

Cihazınızda bir arıza meydana gelirse, lütfen bayinizi aramadan önce aşağıdaki tabloyu kontrol edin..

Hata	Muhtemel Neden	Çözüm
Cihaz çalışmıyor	Ünite açık değil	Ünitenin doğru şekilde takılı ve açık olduğundan emin olun
	Fiş ve kablo hasarlı	Acentenizi veya kalifiye teknisyeninizi arayın
	Fişteki sigorta atmış	Sigortayı değiştirin
	Power supply	Güç kaynağını kontrol edin
	Dahili kablolama hatası	Acentenizi veya kalifiye teknisyeninizi arayın
Cihaz açılıyor, ancak sıcaklık çok yüksek/düşük	Buharlaştırıcıda çok fazla buz var	Cihazın buzunun çözülmesi
	Kondansatör tozla tıkanmış	Acentenizi veya kalifiye teknisyeninizi arayın Damlama tepsisini boşaltın (varsa)
	Kapılar düzgün kapatılmamış	Kapıların kapalı ve contaların hasarlı olmadığını kontrol edin
	Cihaz bir ısı kaynağının yakınında bulunuyor veya kondansatöre giden hava akışı kesiliyor	Buzdolabını daha uygun bir yere taşıyın
	Ortam sıcaklığı çok yüksek	Havalandırmayı artırın veya cihazı daha soğuk bir konuma taşıyın
	Cihazda uygun olmayan gıda maddeleri saklanıyor	Fanın aşırı sıcak yiyeceklerini veya tıkanıklıklarını giderin
	Cihaz aşırı yüklendi	Cihazda saklanan yiyecek miktarını azaltın
Cihaz su sızdırıyor	Cihaz düzgün bir şekilde dengelenmemiş	Cihazı dengelemek için vidalı ayakları ayarlayın (cihaz varsa)
	Tahliye çıkışı tıkalı	Deşarj çıkışını temizleyin
	Suyun tahliyeye doğru hareketi engelleniyor	Cihazın tabanını temizleyin (varsa)
	Su kabı hasarlı	Acentenizi veya kalifiye teknisyeninizi arayın
	Damlama tepsisi taşıyor	Damlama tepsisini boşaltın (eğer varsa)
Cihaz alışılmadık derecede gürültülü	Gevşek somun/vida	Tüm somunları ve vidaları kontrol edin ve sıkın
	Cihaz düz veya sabit bir konuma monte edilmemiştir	Montaj pozisyonunu kontrol edin ve gerekirse değiştirin

## Teknik Özellikler (R290)

Model	Voltaj	Akım	Soğutma Derecesi	Kapasite (litre)	Ebat Y×G×D (mm)	Ağırlık (Kg)
GN2100BT	220-240V 50Hz	3.0A	-10°C ~ -20°C	314 Vn:206	1360×700×860	97
GN3100BT	220-240V 50Hz	3.0A	-10°C ~ -20°C	465 Vn:309	1795×700×860	117
GN4100BT	220-240V 50Hz	4.0A	-10°C ~ -20°C	616 Vn:412	2230×700×860	146

Model	Voltaj	Akım	Soğutma Derecesi	Kapasite (litre)	Ebat Y×G×D (mm)	Ağırlık (Kg)
GN2200BT	220-240V 50Hz	3.0A	-10°C ~ -20°C	314 Vn:206	1360×700×960	103
GN3200BT	220-240V 50Hz	3.0A	-10°C ~ -20°C	465 Vn:309	1795×700×960	130
GN4200BT	220-240V 50Hz	4.0A	-10°C ~ -20°C	616 Vn:412	2230×700×960	160
SNACK2100BT	220-240V 50Hz	3.0A	-10°C ~ -20°C	260 Vn:172	1360×600×860	86
SNACK3100BT	220-240V 50Hz	3.0A	-10°C ~ -20°C	386 Vn:258	1795×600×860	107
SNACK4100BT	220-240V 50Hz	4.0A	-10°C ~ -20°C	511 Vn:344	2230×600×860	133
SNAC2200BT	220-240V 50Hz	3.0A	-10°C ~ -20°C	260 Vn:172	1360×600×960	99
SNACK3200BT	220-240V 50Hz	3.0A	-10°C ~ -20°C	386 Vn:258	1795×600×960	120
SNACK4200BT	220-240V 50Hz	4.0A	-10°C ~ -20°C	511 Vn:344	2230×600×960	147
GN2100TN	220-240V 50Hz	1.2A	-2°C ~ +8°C	314 Vn:206	1360×700×860	93
GN2100TNG	220-240V 50Hz	1.2A	+2°C ~ +8°C	314	1360×700×860	98
GN2200TN	220-240V 50Hz	1.2A	-2°C ~ +8°C	314 Vn:206	1360×700×960	95
GN2200TNG	220-240V 50Hz	1.2A	+2°C ~ +8°C	314	1360×700×960	100
GN3100TN	220-240V 50Hz	1.2A	-2°C ~ +8°C	465 Vn:309	1795×700×860	114
GN3100TNG	220-240V 50Hz	1.2A	+2°C ~ +8°C	465	1795×700×860	126
GN3200TN	220-240V 50Hz	1.2A	-2°C ~ +8°C	465 Vn:309	1795×700×960	125
GN3200TNG	220-240V 50Hz	1.2A	+2°C ~ +8°C	465	1795×700×960	137
GN4100TN	220-240V 50Hz	1.3A	-2°C ~ +8°C	616 Vn:412	2230×700×860	138
GN4100TNG	220-240V 50Hz	1.3A	+2°C ~ +8°C	616	2230×700×860	150
GN4200TN	220-240V 50Hz	1.3A	-2°C ~ +8°C	616 Vn:412	2230×700×960	152
GN4200TNG	220-240V 50Hz	1.3A	+2°C ~ +8°C	616	2230×700×960	164
PA2100TN	220-240V 50Hz	1.2A	+2°C ~ +8°C	428 Vn:304	1510×800×860	105
PA2200TN	220-240V 50Hz	1.2A	+2°C ~ +8°C	428 Vn:304	1510×800×960	116

Model	Voltaj	Akım	Soğutma Derecesi	Kapasite (litre)	Ebat Y×G×D (mm)	Agırlık (Kg)
PA3100TN	220-240V 50Hz	1.3A	+2°C ~ +8°C	635 Vn:456	2020×800×860	132
PA3200TN	220-240V 50Hz	1.3A	+2°C ~ +8°C	635 Vn:456	2020×800×960	146
SNACK2100TN	220-240V 50Hz	1.2A	-2°C ~ +8°C	260 Vn:172	1360×600×860	81
SNACK2100TNG	220-240V 50Hz	1.2A	+2°C ~ +8°C	260	1360×600×860	95
SNACK2200TN	220-240V 50Hz	1.2A	-2°C ~ +8°C	260 Vn:172	1360×600×960	94
SNACK2200TNG	220-240V 50Hz	1.2A	+2°C ~ +8°C	260	1360×600×960	108
SNACK3100TN	220-240V 50Hz	1.2A	-2°C ~ +8°C	386 Vn:258	1795×600×860	102
SNACK3100TNG	220-240V 50Hz	1.2A	+2°C ~ +8°C	386	1795×600×860	116
SNACK3200TN	220-240V 50Hz	1.2A	-2°C ~ +8°C	386 Vn:258	1795×600×960	115
SNACK3200TNG	220-240V 50Hz	1.2A	+2°C ~ +8°C	386	1795×600×960	129
SNACK4100TN	220-240V 50Hz	1.3A	-2°C ~ +8°C	511 Vn:344	2230×600×860	126
SNACK4100TNG	220-240V 50Hz	1.3A	+2°C ~ +8°C	511	2230×600×860	130
SNACK4200TN	220-240V 50Hz	1.3A	-2°C ~ +8°C	511 Vn:344	2230×600×960	140
SNACK4200TNG	220-240V 50Hz	1.3A	+2°C ~ +8°C	511	2230×600×960	155
U-GN2100TN	220-240V 50Hz	1.2A	-2°C ~ +8°C	214 Vn:130	1360×700×650	80
U-GN2140TN	220-240V 50Hz	1.2A	-2°C ~ +8°C	214 Vn:130	1360×700×650	93
U-GN3100TN	220-240V 50Hz	1.2A	-2°C ~ +8°C	317 Vn:195	1795×700×650	104
U-GN3160TN	220-240V 50Hz	1.2A	-2°C ~ +8°C	317 Vn:195	1795×700×650	123
U-GN4100TN	220-240V 50Hz	1.3A	-2°C ~ +8°C	420 Vn:260	2230×700×650	125
U-GN4180TN	220-240V 50Hz	1.3A	-2°C ~ +8°C	420 Vn:260	2230×700×650	150
SH2000/700	220-240V 50Hz	1.3A	+2°C ~ +8°C	396	1360×700×1085	100
SH2000/800	220-240V 50Hz	1.3A	+2°C ~ +8°C	459	1510×800×1085	115
SH3000/700	220-240V 50Hz	1.3A	+2°C ~ +8°C	470	1795×700×1085	121
SH3000/800	220-240V 50Hz	1.3A	+2°C ~ +8°C	576	2020×800×1085	145
PZ1610TN	220-240V 50Hz	1.2A	+2°C ~ +8°C	221	1515×800×1000	256
PZ2600TN	220-240V 50Hz	1.2A	+2°C ~ +8°C	428 Vn:304	1510×800×1000	234

Model	Voltaj	Akım	Soğutma Derecesi	Kapasite (litre)	Ebat Y×G×D (mm)	Ağırlık (Kg)
PZ2610TN	220-240V 50Hz	1.2A	+2°C ~ +8°C	428 Vn:304	2025×800×1000	334
PZ3600TN	220-240V 50Hz	1.3A	+2°C ~ +8°C	635 Vn:456	2025×800×1000	294

## Elektrik Diyagramı

Cihazlar, standart olarak 13 amperlik bir sigorta ile birlikte 3 uçlu, kalıplanmış, BS1363 fiş ve kablo ile birlikte tedarik edilir. Fiş, uygun bir şebeke prizine bağlanmalıdır. Cihazlar aşağıdaki şekilde kablolanır:

- Canlı tel (kahverengi renkli) L işaretli terminale
- Nötr tel (mavi renkli) N işaretli terminale
- Toprak teli (yeşil/sarı renkli) E işaretli terminale

Tüm cihazlar, özel bir topraklama devresi kullanılarak topraklanmalıdır. Şüphenez varsa kalifiye bir elektrikçiye danışın. Elektrik izolasyon noktaları herhangi bir engelden uzak tutulmalıdır. Herhangi bir acil bağlantı kesilmesi gerektiğinde kolayca erişilebilir olmalıdırlar

## İmha Etme

AB yönetmelikleri, soğutma ürünlerinin tüm gazları, metal ve plastik bileşenleri çıkaran veya geri dönüştüren uzman şirketler tarafından atılmasını gerektirir.

Cihazınızın atılması konusunda yerel atık toplama yetkilinize danışın. Yerel yetkililer ticari soğutma ekipmanlarını atmaktan yükümlü değildir ancak ekipmanın yerel olarak nasıl atılacağı konusunda tavsiyelerde bulunabilirler..

## Uyumluluk

Parçalar, uluslararası, bağımsız ve federal otoriteler tarafından belirlenen düzenleyici standartlara ve özelliklere uymak için sıkı ürün testlerinden geçmiştir.

Ürünlerin aşağıdaki sembolü taşıması onaylanmıştır.

**Bu buzdolabında R600a ve R290 soğutucu akışkanı kullanılmıdır**



### UYARILAR:

Cihaz muhafazasındaki veya yerleşik yapıdaki havalandırma açıklıklarını tıkanıklıktan uzak tutun. Üretici tarafından önerilenler dışında, buz çözme işlemini hızlandırmak için mekanik cihazlar veya başka araçlar kullanmayın.

Soğutucu devresine zarar vermeyin.

Üretici tarafından önerilen tipte olmadıkları sürece, cihazın gıda saklama bölmelerinin içinde elektrikli cihazlar kullanmayın..





BESLEME KABLOSU HASAR GÖRMÜŞSE, SATIŞ SONRASI SERVİS ÜRETİCİSİ VEYA KALİFİYE TEKNİSYEN, HERHANGİ BİR OLASI RİSKİ ÖNLEMELİK İÇİN BUNU DEĞİŞTİRECEKTİR.

LAMBA ONARIMI VE DEĞİŞİMİ, GÜÇ KAYNAĞI KESİLMİŞ OLMASI HALİNDE, KALİFİYE TEKNİSYENLER TARAFINDAN YAPILMALIDIR. AYNI LAMBALARLA DEĞİŞTİRİLMELİDİR.

SADECE KALİFİYE TEKNİSYENLER, OLAĞANÜSTÜ BAKIM MÜDAHALELERİNİ GERÇEKLEŞTİRECEKTİR..



Ambalajın atılması

Tüm ambalaj malzemeleri çevre dostu bir şekilde atılmalıdır.

Karton, hurda kağıt olarak kullanılabilir. Koruyucu folyo ve köpük yastıklar CFC içermez.

Çocukların ambalajla oynamasına izin vermeyin ve plastik poşetleri güvenli bir şekilde imha edin.

Kartonu kırabilir veya daha küçük parçalara kesebilir ve bir atık kağıt imha servisine verebilirsiniz..



Çevre koruma

Atılan elektrikli cihazlar geri dönüştürülebilir ve evsel atıklarla birlikte atılmamalıdır! Lütfen bu cihazı toplama merkezlerine (mümkünse) geri göndererek kaynakları koruma ve çevreyi koruma konusunda bizi aktif olarak destekleyin.